



Circular H 22 /2020

TO ALL SMS MEMBERS/ ALL FACILITY MANAGERS/ THE CITY OF CAPE TOWN/ HIGHER EDUCATION INSTITUTIONS/ PRIVATE SECTOR

WESTERN CAPE PREPAREDNESS FOR COVID-19 CASES

1. BACKGROUND AND CONTEXT

The first person who tested positive for coronavirus (COVID-19) in South Africa was reported last Thursday (5 March 2020) in KwaZulu Natal in a man returning from Italy on Thursday 5 March. A further 13 individuals who had tested positive have now been confirmed including one in the Western Cape. The patient in the Western Cape is a 36-year-old man who had travelled to multiple European countries. Contact tracing is underway. At this stage South Africa is classified as having imported disease only. No local transmission has yet been documented.

2. PURPOSE

The Circular aims to update you regarding the Provincial response, provide initial resources and links to other resource documents. It further aims to request that you ensure the alertness and readiness of your facilities as outlined broadly below.

3. ESTABLISHING THE JOINT OPERATIONS COMMAND CENTRE

The Western Cape Department of Health has officially convened the Provincial Joint Operations Centre (PJOC) and is working to:

- a) Identify, isolate and care for patients early across both public and private health sectors
- b) Follow-up and isolate contacts of confirmed or suspected cases to delay local transmission
- c) Communicate relevant information regarding local protocols to staff
- d) Address the spread of misinformation
- e) Prepare facilities to manage suspected and confirmed cases
- f) Ensure measures to protect health workers are fully implemented

4. ENSURING FACILITY READINESS

The following high-level functions have been identified to ensure facility readiness:

- a) Ensure a facility IPC (Infection Prevention Control) plan is in place.

- b) Convene a meeting with **all** staff, including clerical, cleaning and security staff to inform them of the contents of this Circular and work through the materials provided.
- c) Ensure that good hand and respiratory hygiene practices are in place at the facility with continued reminders to all staff.
- d) Ensure that all staff are familiar with the Person Under Investigation (PUI) definition for COVID-19.
- e) Ensure that sufficient supplies of protective equipment (gloves, N95 and surgical masks, aprons, gowns if appropriate, eye visors) are available at the facility AND securely stored.
- f) Identify an area of the facility where a person under investigation (PUI) can be isolated and managed immediately on arrival at the facility (see definition of a PUI below).
- g) Run a practice drill for a person presenting to the facility with suspected COVID-19 ensuring that clinic staff are aware how to:
 - Isolate a person with suspected COVID-19
 - Put on protective wear
 - Know which specialist to contact and have this number clearly visible in all consulting areas/ designated isolation area.
 - Provide initial management to the patient, including oxygen if needed.
 - Complete collection of naso- and oro-pharyngeal swabs (including completion of forms)
 - Document close contacts and notify Provincial Communicable Disease Control
 - Arrange for transfer to hospital or discharge as advised
 - Discard protective wear, disinfect and notify Facility Manager
 - Have critical telephone numbers readily available

5. PERSONS UNDER INVESTIGATION

The **definition for a Person Under Investigation (PUI)** is as follows:

Persons with acute respiratory illness with sudden recent onset of at least one of the following: cough, shortness of breath or fever [$\geq 38^{\circ}\text{C}$ (measured) or history of fever (subjective)] irrespective of admission status AND

In the 14 days prior to onset of symptoms, met at least one of the following criteria:

- Were in close contact with a confirmed or probable case of COVID-19;
OR
- Had a history of travel to areas with presumed ongoing community transmission of COVID-19; i.e., China, South Korea, Japan, Iran, Hong Kong, Italy, and Taiwan (NB Affected countries are rapidly changing all the time, Consult the NICD website for current updates);
OR
- Worked in, or attended a health care facility where patients with COVID-19 infections were being treated;
OR
- Admitted with severe pneumonia of unknown aetiology

6. COVID-19 vs INFLUENZA

Whilst symptoms with COVID-19 infection are similar to the symptoms of the normal influenza infection (i.e. fever, cough, myalgia); there are some important differences. More people with COVID-19 develop severe symptoms and the mortality rate is higher. COVID-19 also spreads more easily than influenza. Both influenza and COVID-19 are spread by contact, droplets and objects which have been touched, coughed or sneezed on by infected people. Prevention is through good hand hygiene, respiratory etiquette and avoiding close contact with those who are unwell without protection or touching your face.

Characteristic	Influenza	COVID-19
Symptoms	Fever, cough, myalgia, sore throat, runny nose	Similar although sore throat and runny nose less common Fever > 38° C
Populations at risk of severe illness	Young, elderly, pregnant women, underlying health conditions or immunosuppression	Elderly, immunocompromised individuals, underlying health condition, health care workers
Incubation period (time from infection to symptom onset)	3 days	5 days (but can be up to 14 days)
Pre-symptomatic transmission period (time during which infectious and asymptomatic)	3-5 days	1-2 days (provisional)
Natural history	1-2% severe disease requiring hospitalisation	81% self-limiting illness 14% severe disease (requiring oxygen) 5% critical disease (respiratory failure, septic shock and/or multiple organ dysfunction requiring ICU support).
Mortality rate	0.1%	Not yet determined and depends on access to and quality of care. Estimates between 1 and 4%.
Prevention	Hand hygiene General hygiene Cough etiquette	Hand hygiene General hygiene Cough etiquette

	Annual influenza vaccine	Avoiding close contact with those who are unwell without protection A vaccine is only expected in 2021
Treatment	Supportive Antivirals	Supportive only. No specific treatment yet determined.

7. SUPPORTING INFORMATION

The following **reference documents** are attached:

1. Coronavirus disease (COVID-19) Step-by-step for the health care worker (Updated 11 March 2020).
2. Protect yourself from coronavirus disease (COVID-19) pamphlet for patients and the public (Updated 11 March 2020).
3. Coronavirus disease 2019 (COVID-19) caused by a Novel Coronavirus (SARS-CoV-2): Guidelines for case-finding, diagnosis, management and public health response in South Africa (NICD and National Department of Health: Version 2.0, 8 March 2020)

Please note that all guidance and information provided is subject to change depending on the stage of the epidemic and the capacity of the health system. For more information, please see:

www.westerncape.gov.za/departments-of-health/coronavirus



Dr B Engelbrecht

Head of Department: Health

Western Cape Government: Health

Date: 11 March 2020

Coronavirus (COVID-19)

Step-by-step for the health care worker

When to suspect COVID-19:

- Patient with recent onset of any of: cough, fever, shortness of breath or sore throat
AND
 In the 14 days prior to onset of symptoms had any of: Close contact with a confirmed or probable case of COVID-19
OR
 History of travel to area known with COVID-19
OR
 Worked in or attended a health care facility where patients with 2019-nCoV infections were being treated.

If COVID-19 suspected, what to do:

1 Prevent and control infection

- Stay calm. Most people with COVID-19 have a mild illness.
- Put on your N95 mask, apron and gloves .
- Put a surgical mask on the patient.
- Isolate the patient (in same room if possible - avoid moving patient through facility).
- Wash hands regularly and use > 70% alcohol sanitizer. Avoid touching your face.

2 Consult a specialist

- Contact Infectious Disease specialist/virologist at:
 - Tygerberg: **083 419 1452** or 021 938 4911 or 021 938 9645
 - Grootte Schuur: **021 404 9111**
 - Provincial Health Operations Centre: **021 938 0300**
- **AND**
- Phone NICD hotline at **082 883 9920** or text your name and query to: **066 562 4021**.

3 Manage and/or refer

- If patient has difficulty breathing, give oxygen.
- Follow instruction from ID specialist/NICD to:
 - Manage further or refer.
 - Collect naso- and oro-pharyngeal swabs and/or other specimens (e.g bloods).
 - Complete request forms (scan and email to ncov@nicd.ac.za before sending specimens):
 - Patient Under Investigation (PUI) form: Request for 2019-nCov Testing)
 - Centre for Respiratory and Meningitis Specimen Submission form

4 Notify and report close contacts

Phone Provincial Communicable Disease Control (CDC) on any of:

021 483 9964 | 021 483 3156 | 021 483 6878 | 072 356 5146 | 073 177 4735

Complete case notification form (paper-based or electronic) and send list of close contacts* to ncov@nicd.ac.za

*Close contacts include: those in the same household or workplace; health care workers (not wearing protective gear) or caregivers; those with whom patient has had face-to face contact or been in a closed environment. If recent air travel: record flight details.

5 Clean and disinfect

- Discard all waste and non-reusable medical equipment used in medical waste box
- Disinfect equipment with 70% ethyl alcohol
- Clean and disinfect environment using soap & water followed by sodium hypochlorite solution

If case confirmed by specialist as suspected COVID-19: contact Facility Manager, limit movement and await further instructions so that the Department of Health can ensure you receive appropriate care.

Protect yourself from coronavirus (COVID-19)



What is Coronavirus (COVID-19)?

- A respiratory illness similar to flu (cough, fever, fatigue & aching body/muscles). More commonly than flu, it can become severe causing viral pneumonia (difficulty breathing).
- 4 out of 5 people will have a mild illness and recover without treatment. The elderly and those with underlying health conditions have increased risk of severe illness. Cases in children are rare.

How does it spread?

You can pick up Coronavirus from:

- Touching an infected surface or object. The virus can enter your body when you touch your nose, mouth and eyes.
- Very close contact (1-2 metres) with a sick patient.



Prevent spread to keep you and your family safe:

- Cover your mouth and nose with a tissue or your sleeve/elbow (not your hands) when coughing/sneezing. Discard used tissues immediately and wash your hands.
- Avoid close contact with those who are sick. Wearing a mask is unlikely to protect you if you are well. People who are coughing and sneezing who wear a mask are less likely to infect others.
- Avoid touching face, eyes, nose or mouth.
- Clean and disinfect frequently touched objects and surfaces (counters, bedside table, doorknobs, bathroom surfaces, phones).
- Wash hands often, especially before handling food/after using toilet or coughing/sneezing.



Wash your hands well

- Use these steps to wash your hands for at least 20 seconds.
- Roll up your sleeves, rinse hands in clean water and apply soap to palm of hand.



1 Rub palms together.



2 Rub fingers between each other.



3 Place one hand over back of other, rub between fingers. Swap hands.

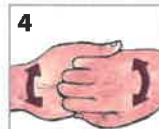

4 Grip fingers and rub together.



5 Rub each thumb with opposite palm. Swap hands.



6 Rub tips of nails against palm. Swap hands.

- Rinse your hands with clean water and dry on paper towel or allow to dry on their own.

General Public Hotline **0800 029 999**. Operating 24 hours per day.

For more information: www.westerncape.gov.za/departement-of-health/coronavirus



Disclaimer: This information should not be considered as medical advice. It is not a replacement for a visit with a nurse, doctor or other healthcare professional. If you have concerns about your individual medical situation, please see a healthcare professional. This information is provided on an "as is" basis without any warranties regarding accuracy, relevance, usefulness or fitness for purpose. You use this information at your sole risk.

What if I develop symptoms?



What are the symptoms of COVID-19?

- The more common symptoms of COVID-19 are the same as flu and include: fever, cough, difficulty breathing, fatigue, body/muscle aches.
- Currently very few people have been confirmed with COVID-19 in South Africa.

When should I be concerned that I may have COVID-19?

Only suspect COVID-19 if you have a fever with a cough or shortness of breath AND have in the last 14 days:

- a) travelled internationally or to an area with confirmed COVID-19 cases

OR

- b) had close contact with a confirmed or suspected case of COVID-19

If you are feeling short of breath or have difficulty breathing, seek health care urgently.

Call ahead to your doctor or alert health facility as soon as you arrive; tell them about your symptoms and any recent travel/contacts. Expect to put on a mask before you enter the facility.

What should I do if I think I have COVID-19?

- Do not panic.
- First, phone General Public Helpline **0800 029 999** and follow their advice.
- Stay home, except to get medical care as directed by the helpline. Do not go to work, school, or public areas. Avoid using public transport or taxis.
- Rest, ensure you drink plenty of fluids and use medications (like paracetamol) as needed to reduce fever and/or pain.
- Avoid close contact with those who are sick. When in contact with others, wear a mask if available.
- Avoid sharing dishes, drinking glasses, cups, eating utensils, towels, or bedding – after using these, wash them well.
- Use strict prevention measures listed on the other side of this leaflet.
- Only discontinue home isolation in consultation with helpline/ healthcare provider (usually 14 days).

The most important thing you can do is to prevent spread to keep you, your family and your community safe.



Disclaimer: This information should not be considered as medical advice. It is not a replacement for a visit with a nurse, doctor or other healthcare professional. If you have concerns about your individual medical situation, please see a healthcare professional. This information is provided on an "as is" basis without any warranties regarding accuracy, relevance, usefulness or fitness for purpose. You use this information at your sole risk.

Coronavirus disease 2019 (COVID-19) caused by a Novel Coronavirus (SARS-CoV-2)

Guidelines for case-finding, diagnosis, management and public health response in South Africa

Compiled by

**the Centre for Respiratory Diseases and Meningitis and Outbreak Response, Division of
Public Health Surveillance and Response, National Institute for Communicable Diseases
(NICD) of the National Health Laboratory Services (NHLS)**

and

the National Department of Health, South Africa

Version 2.0

Guidelines writing committee (in alphabetical order):

Ahmed Bham (National Department of Health (NDoH), Emergency Medical Services (EMS))

Jinal Bhiman ((National Institute for Communicable Diseases (NICD); Centre for Respiratory Diseases and Meningitis (CRDM))

Funeka Bongweni (NDoH, Port Health)

Lucille Blumberg (NICD, Division of Public Health Surveillance and Response (DPHSR))

Cheryl Cohen (NICD, CRDM)

Linda Erasmus (NICD, DPHSR)

Jackie Kleynhans (NICD, CRDM)

Nevashan Govender (NICD, DPHSR)

Ann Mathews (NICD, DPHSR)

Kerrigan McCarthy (NICD, DPHSR)

Meredith McMorrow (U.S. Centers for Disease Control and Prevention (CDC))

Jeremy Nel (Helen Joseph Hospital)

Genevieve Ntshoe (Helen Joseph Hospital)

Wayne Ramkrishna (NDoH)

Stefano Tempia (CDC)

Sibongile Walaza (NICD, CRDM)

Nicole Wolter (NICD, CRDM)

Guideline review:

This version (2.0) approved by: Cheryl Cohen and Wayne Ramkrishna

Date: 08/03/2020

Summary of changes:

Version	Date reviewed	Reviewed by	Summary of changes	New version #
1.0	26 February 2020	S. Walaza and M McMorrow	<ul style="list-style-type: none">• 2019 nCoV changed to COVID-19 or SARS-CoV-2 as appropriate• Updated case counts, etc.• Updated contributors• Updated case definition to add fever, pneumonia of unknown aetiology and countries with community transmission of COVID-19	1.1

			<ul style="list-style-type: none"> • Update information on packaging of specimens-triple packaging only applicable to international specimens) • Additional information on differential diagnosis and treatment added 	
1.1	8 March 2020	S. Walaza and M. McMorrow	<ul style="list-style-type: none"> • Updated general epidemiologic information on outbreak • Updated information on first confirmed cases in South Africa • Clarified that contact information should be collected from contacts from the date of symptom onset • Updated referral hospital list 	2.0

Disclaimer

The information contained in this document, be it guidelines, recommendations, diagnostic algorithms or treatment regimens, are offered in this document in the public interest. To the best of the knowledge of the guideline writing team, the information contained in these guidelines is correct. Implementation of any aspect of these guidelines remains the responsibility of the implementing agency in so far as public health liability resides, or the responsibility of the individual clinician in the case of diagnosis or treatment.

Quick Reference Guide – COVID-19

Criteria for person under investigation (PUI) (Page 10):

Persons with acute respiratory illness with sudden onset of at least one of the following: cough, sore throat, shortness of breath or fever [$\geq 38^{\circ}\text{C}$ (measured) or history of fever (subjective)] irrespective of admission status **AND**

In the 14 days prior to onset of symptoms, met at least one of the following epidemiological criteria:

- Were in close contact¹ with a confirmed² or probable³ case of SARS-CoV-2 infection;
- OR**
- Had a history of travel to areas with presumed [ongoing community transmission of SARS-CoV-2](#); i.e., China, South Korea, Japan, Iran, Hong Kong, Italy, and Taiwan (NB Affected countries will change with time, consult the NICD website for current updates);
- OR**
- Worked in, or attended a health care facility where patients with SARS-CoV-2 infections were being treated;
- OR**
- Admitted with severe pneumonia of unknown aetiology

¹ Close contact: A person having had face-to-face contact or was in a closed environment with a COVID-19 case; this includes, amongst others, all persons living in the same household as a COVID-19 case and, people working closely in the same environment as a case. A healthcare worker or other person providing direct care for a COVID-19 case, while not wearing recommended personal protective equipment or PPE (e.g., gowns, gloves, NIOSH-certified disposable N95 respirator, eye protection). A contact in an aircraft sitting within two seats (in any direction) of the case, travel companions or persons providing care, and crew members serving in the section of the aircraft where the case was seated. ² Confirmed case: A person with laboratory confirmation of SARS-CoV-2 infection, irrespective of clinical signs and symptoms. ³ Probable case: A PUI for whom testing for SARS-CoV-2 is inconclusive (the result of the test reported by the laboratory) or who tested positive on a pan-coronavirus assay.

Clinicians should also be vigilant for the possibility of atypical clinical presentations among immunocompromised patients. Consider the possibility of influenza (Northern Hemisphere season ends in April or May) and bacterial pneumonia and manage accordingly.

Infection control: Pages 10-12

Mode of transmission is typically respiratory droplet for human coronaviruses. Because patients may require aerosol-generating procedures, airborne precautions are preferred where possible.

1. Early detection is key - healthcare workers should maintain a high level of clinical suspicion
2. Patients should wear a surgical mask as soon as they are identified, and evaluated in a private room
3. Isolate PUI (ideally an airborne infection isolation room if available)
4. Use appropriate infection control for PUI
 - a. Adequate standard precautions for all patients
 - b. Add contact and droplet precautions for all patients
 - c. Apply airborne precautions (eg. N95 mask) and eye protection must be used when performing aerosol-generating procedures
 - d. If available, airborne precautions should be used at all times
 - e. Limit movement of patient (e.g. use designated portable X-ray equipment)

Laboratory diagnosis and specimen collection for SARS-CoV-2 Pages 12-15, Appendices 5-8

Collect appropriate samples. **Lower respiratory tract samples are preferred because the lower respiratory tract is the primary site of infection.**

- **Respiratory samples** - Combined nasopharyngeal and oropharyngeal swabs in ambulatory patients and sputum and/or tracheal aspirate or bronchoalveolar lavage in patients with more severe respiratory disease. Respiratory samples are the primary method of diagnosis.
- **Serum for serological testing** - acute and convalescent samples should be submitted in addition to respiratory samples
- Place swabs together in universal transport medium (UTM), or if not available send in gel or dry, sputum and aspirates in a universal container and clotted tube for serum
- Complete person under investigation form (Appendix 8) and specimen submission form (Appendix 7)
- Transport samples at 2-8°C (in cooler box with ice packs)
- Alert NICD Hotline +27 82 883 9920

A single negative test result, especially if from upper respiratory tract specimen, does not exclude infection. Repeat sampling and testing of lower respiratory tract samples are recommended for cases with severe disease or in whom 2019-nCoV is strongly suspected.

Notification of cases and additional support: Appendix 4

- All PUI should be notified to the district provincial communicable disease control coordinator(CDCC) as per notifiable medical condition procedures (see Appendix 4 and 11 for contact details), or the NICD <http://www.nicd.ac.za/notifiable-medical-conditions/>
- Clinicians should discuss the case with doctor on call before collecting and sending specimens for testing at **NICD Hot line: +27 82 883 9920 or +27 66 562 4021**
- COVID-19 is classified as Category 1 notifiable medical condition; therefore, notification should be made immediately on identification of a case meeting case definition of person under investigation for SARS-CoV-2, a cluster of cases with severe respiratory illness with evidence of common exposure or epidemiologic link, or on receipt of a laboratory diagnosis of SARS-CoV-2 infection. Information available at <http://www.nicd.ac.za/notifiable-medical-conditions/>

1 Table of Contents

1	Introduction	7
2	Microbiology and epidemiology	7
3	Clinical presentation and management.....	8
4	Surveillance and case definitions for COVID-19.....	10
4.1	Rationale for surveillance for COVID-19	10
4.2	Who should be tested for SARS-CoV-2?	10
5	Infection control.....	10
6	Laboratory diagnosis.....	12
6.1	Who should be tested.....	12
6.2	What investigations should be done	12
6.3	Specimen collection and transport.....	13
6.4	Laboratory diagnostic assays and interpretation of results	14
7	Public health response.....	16
7.1	Response to a suspected case	16
7.2	Response to a confirmed case	16
7.3	Contact tracing.....	16
7.4	Management of the deceased.....	18
7.5	Quarantine	18
8	Additional Resources	18
9	Appendices.....	19
9.1	Appendix 1 – process flow for detection and response to cases	20
9.2	Appendix 2 – roles and responsibilities of facility, district, province and national vis a vis information flow	21
9.3	Appendix 3 – flow diagram for contact tracing, screening and monitoring	22
9.4	Appendix 4 – Initial diagnosis and management of suspected case, including infection control measures	23
9.5	Appendix 5: Collection of nasopharyngeal and oropharyngeal swab and nasopharyngeal aspirate	24
9.6	Appendix 6. Procedures for submission of specimens for investigation	26
9.7	Appendix 7 - Specimen submission form.....	29
9.8	Appendix 8– Person under investigation form	30
9.9	Appendix 9 – Contact tracing and contact line list	32
9.10	Appendix 10 – Contact monitoring tool.....	35
9.11	Appendix 11 – Response to suspected case at port of entry.....	36
9.12	Appendix 12 – Guidelines for the safe handling of human remains of confirmed/suspected COVID-19 case and repatriation of human remains of confirmed/suspected COVID-19 case.....	44

9.13 Appendix 13 – Communicable Diseases Outbreak Report Format.....47

9.14 Appendix 14 – Contact details (email address and telephone) of stakeholders involved in supporting outbreak response.....50

1 Introduction

On the 31 December 2019, the World Health Organization (WHO) China country office reported a cluster of pneumonia cases in Wuhan, Hubei Province of China. On 7 January 2020, the causative pathogen was identified as a novel coronavirus (SARS-CoV-2)¹. Initially person-to-person transmission was not apparent and the majority of the cases were epidemiologically linked to a seafood, poultry and live wildlife market (Huanan Seafood Wholesale Market) in Jiangnan District of Hubei Province. However, the number of cases continued to increase rapidly, and evidence of person-to-person transmission mounted in travellers diagnosed with coronavirus disease (COVID-19) who had visited Wuhan².

The WHO International Health Regulations Emergency Committee declared that the outbreak of 2019-nCoV meets the criteria for a Public Health Emergency of International Concern (PHEIC) on 30 January 2020 ([https://www.who.int/news-room/detail/30-01-2020-statement-on-the-second-meeting-of-the-international-health-regulations-\(2005\)-emergency-committee-regarding-the-outbreak-of-novel-coronavirus-\(2019-ncov\)](https://www.who.int/news-room/detail/30-01-2020-statement-on-the-second-meeting-of-the-international-health-regulations-(2005)-emergency-committee-regarding-the-outbreak-of-novel-coronavirus-(2019-ncov))). The WHO assessment of the risk of this event is: very high in China and globally. The daily WHO situation update can be found at: <https://www.who.int/emergencies/diseases/novel-coronavirus-2019/situation-reports>.

In the light of the transmissibility of coronaviruses, and the global experience with MERS-CoV (ongoing) and SARS in 2003 which were also caused by coronaviruses, South African authorities have compiled this guideline document to support surveillance, case finding, diagnosis, management and public health responses to cases under investigation.

THIS SITUATION IS RAPIDLY EVOLVING

BEFORE USING THIS DOCUMENT PLEASE CHECK FOR UPDATES ON THE NICD AND NDOH WEBSITES (www.nicd.ac.za and www.ndoh.gov.za)

**OR CALL YOUR PROVINCIAL COMMUNICABLE DISEASE CO-ORDINATOR
(See Appendix 14 for contact details)**

2 Microbiology and epidemiology

Coronaviruses are enveloped, single-stranded positive-sense RNA viruses. The envelope of the coronaviruses is covered with club-shaped glycoproteins which look like 'crowns', or 'halos' – hence the name 'coronavirus.' Coronaviruses are responsible for the common cold, and usually cause self-limited upper respiratory tract infections. However, in 2003, a new coronavirus emerged leading to the SARS (severe acute respiratory syndrome) outbreak. In 2012, the Middle East respiratory syndrome (MERS) was found to be caused by a coronavirus associated with transmission from camels. Both viruses had a range of clinical presentations from mild upper respiratory tract symptoms and possibly asymptomatic infection, to severe acute respiratory syndrome leading to sepsis, multi-organ failure and death in a sizeable proportion of cases.

¹ World Health Organization (WHO), <https://www.who.int/emergencies/diseases/novel-coronavirus-2019>

² Centers for Disease Control and Prevention (CDC), <https://www.cdc.gov/media/releases/2020/p0130-coronavirus-spread.html>

Following the identification of a cluster of pneumonia cases in Wuhan, Hubei Province of China, Chinese authorities reported on 7 January 2020 that the causative pathogen was identified as a novel coronavirus (2019-nCoV). The gene sequences were deposited in Genbank, the NIH genetic sequence database, and in the Global Initiative on Sharing All Influenza Data (GISAID) portal.

Available evidence, and experience from MERS-CoV and SARS suggests that the novel coronavirus has a possible zoonotic origin. However, human-to-human transmission of SARS-CoV-2 is now confirmed. As of 6 March 2020, over 97,000 cases and 3300 deaths have been reported from 87 countries and territories. The daily WHO situation update can be found at: <https://www.who.int/emergencies/diseases/novel-coronavirus-2019/situation-reports/>. On 5 March 2020, South African Minister of Health Dr. Zweli Mkhize announced the country's first confirmed coronavirus (COVID-19) case. The patient, a 38-year-old male in KwaZulu-Natal Province, returned to South Africa on March 1 after traveling in Italy. He developed symptoms and visited a doctor on March 3 with fever, headache, malaise, sore throat and mild cough, and subsequently self-isolated. The NICD confirmed the positive COVID-19 result and are conducting contact tracing while the patient and his doctor remain in self-isolation. A second case of COVID-19 was notified on 7 March 2020 in a fellow traveller to Italy, and a third case in the same group of travellers on 8 March 2020.

The Chinese Center for Disease Control and Prevention (China CDC) has provided epidemiological information on the first 44,672 cases detected in China³. Approximately 80% of cases were in persons aged 30-69 years, 10% in children and adults aged 0-29 years, and 10% in adults aged 70 years and older. Over 80% of cases had mild symptoms, 13.8% had severe disease, and 4.7% were critically ill. There were 1023 deaths (case-fatality rate (CFR) 2.3%). The CFR was less than 0.5% in persons aged <50 years and increased with increasing age. Co-morbid conditions were reported more commonly in fatal cases. Early estimates of transmission parameters are as follows (obtained from the first 425 confirmed cases): mean incubation period 5.2 days (95% confidence interval [CI], 4.1 to 7.0), mean serial interval 7.5 (95%CI: 5.3-19) days and basic reproductive number 2.2 (95%CI: 1.4-3.9)⁴.

3 Clinical presentation and management

A minority, but not negligible proportion of patients have had acute, serious respiratory illness with fever, cough, shortness of breath, and breathing difficulties. Severity of illness was defined according to any of the following criteria: (i) shortness of breath; (ii) respiratory rate >30 bpm in an adult; (iii) hypoxemia; and (iv) chest X-ray with multi-lobe infiltrates or pulmonary infiltration progressing >50% within 24-48 hours. Because investigations initially focused on severe cases the severity of the infection may be overestimated among the currently known confirmed cases.

The clinical features of 41 severe cases initially detected in China have been described in detail. These patients were hospitalized in a dedicated hospital in Wuhan city. 73% were men, the median age was 49 years (IQR: 41-58 years) and 66% had been exposed to Huanan seafood market. 32% had underlying medical conditions, including diabetes (20%), hypertension (15%) and cardiovascular disease (15%). Common symptoms at onset included fever (98%), cough (76%) and myalgia or fatigue (44%). Less common symptoms were headache (8%), haemoptysis (5%) and diarrhoea (3%). Dyspnoea developed

³ Chinese Center for Disease Control and Prevention. The epidemiological characteristics of an outbreak of 2019 Novel Coronavirus Diseases (COVID-19) – China, 2020. China CDC Weekly, 2020.

⁴ Li et al. Early Transmission Dynamics in Wuhan, China, of Novel Coronavirus-Infected Pneumonia, *N Engl J Med*, 2020.

in 22% of patients. The median time of dyspnoea development was 8 days (IQR: 0-13 days). 63% of patients had lymphopenia and all patients had pneumonia with abnormal findings on chest X-ray. Complications included acute respiratory distress syndrome (29%) and acute cardiac injury (19%). 32% of patients were admitted to an ICU and 15% died⁵.

Another description of the clinical characteristic of 99 confirmed cases from China reported a median age of 55.5 years. 51% of patients had chronic diseases, 83% had fever, 82% had cough, 31% had shortness of breath, 11% had muscle ache, 9% had confusion, 8% had headache, 5% had sore throat, 4% had rhinorrhoea, 2% had chest pain, 2% had diarrhoea and 1% had nausea and vomiting. 75% of patients showed bilateral pneumonia, 14% showed multiple mottling and ground-glass opacity and 1% had pneumothorax. 17% of patients developed acute respiratory distress syndrome and of those 11% worsened rapidly and died of multiple organ failure⁶. More clinical information is expected to emerge if cases increase, especially among patients with mild clinical presentation.

There is currently no specific treatment for disease caused by SARS-CoV-2 infection. It is important to keep a broad differential diagnosis (bacterial pneumonia, atypical bacterial pneumonia, other viral pneumonias including influenza, *Pneumocystis* pneumonia) until diagnosis is confirmed and to provide supportive care for a Severe Acute Respiratory Illness (SARI) or based on patient symptoms. Supportive management of SARI includes among others oxygen if required, ventilator support if required, restrictive fluid management (unless shock or acute kidney injury), and other standard supportive measures in critically ill patients.

There is early evidence that some medications used to treat HIV (lopinavir, ritonavir) may benefit patients with COVID-19 infection but further data are needed. The WHO interim clinical care guidance can be found at: <https://www.who.int/emergencies/diseases/novel-coronavirus-2019/technical-guidance>. Severe pneumonias generally require broad-spectrum antibiotics empirically and current protocols/guidelines should be followed <https://www.ncbi.nlm.nih.gov/pmc/articles/PMC5506119/>. Routine administration of corticosteroids should be avoided, and should only be used if, after careful consideration, risks outweigh benefits (eg. Adrenal insufficiency, COPD, *Pneumocystis* pneumonia). Although corticosteroids may be of benefit in severe bacterial pneumonias, they have been associated with prolonged viral shedding and increased mortality in influenza. Atypical bacterial pneumonias are an important differential diagnosis of a viral pneumonia. Like a viral pneumonia these may have flu-like symptoms and bilateral infiltrates on X-ray. Infiltrates can appear reticulonodular/patchy, not necessarily consolidation. Empiric treatment options include a Macrolide (eg. Azithromycin) OR Quinolone (eg. Levofloxacin, moxifloxacin) OR Doxycycline.

Causes of viral pneumonias include influenza, parainfluenza, human metapneumovirus, respiratory syncytial virus, adenovirus etc. Influenza is an important differential diagnosis to consider as it is currently influenza season in the Northern hemisphere where many COVID suspects will have come from and it is potentially treatable. Empiric oseltamivir (Tamiflu) or zanamivir treatment should be considered in patients with an influenza-like illness who are severely ill or are at high risk for complications (pregnant women, HIV-infected patients, patients with asthma/COPD etc). Treatment should be started as soon as possible, with best chance of benefit within 48 hours of symptom onset). Oseltamivir 75mg po 12-hourly for 5 days. For more information; see NICD Influenza Guidelines

⁵ Huang et al. Clinical features of patients infected with 2019 novel coronavirus in Wuhan, China. *Lancet*, 2020.

⁶ Chen et al. Epidemiological and clinical characteristics of 99 cases of 2019 novel coronavirus pneumonia in Wuhan, China: a descriptive study. *Lancet*, 2020.

<http://www.nicd.ac.za/wp-content/uploads/2019/06/influenza-guidelines-rev-6-June-2019clean.pdf>. *Pneumocystis jirovecii* pneumonia should be considered in patients who are

significantly immunocompromised: HIV-positive with CD4<200, chronic systemic steroid use, chemotherapy, transplant patients, etc.) with diffuse bilateral infiltrates on X-ray (often mid to lower zone predominance) and hypoxemia at rest (or with exertion in mild cases). Consider empiric treatment as per local guidelines if these criteria are met.

4 Surveillance and case definitions for COVID-19

4.1 Rationale for surveillance for COVID-19

Surveillance for COVID-19 is essential to permit early recognition of suspected cases, early diagnosis, containment and prevention of further cases. Surveillance should be conducted by all clinicians and health facilities. Staff should be aware of the surveillance case definitions, and implement routine screening where appropriate (e.g. on returning travellers from affected areas).

4.2 Who should be tested for SARS-CoV-2?

Surveillance case definitions for persons under investigation (PUI) who should be tested for COVID-19

Persons with acute respiratory illness with sudden onset of at least one of the following: cough, sore throat, shortness of breath or fever [$\geq 38^{\circ}\text{C}$ (measured) or history of fever (subjective)] irrespective of admission status **AND**

In the 14 days prior to onset of symptoms, met at least one of the following epidemiological criteria:

- Were in close contact with a confirmed or probable case of SARS-CoV-2 infection;
- OR
- Had a history of travel to areas with presumed [ongoing community transmission of 2019-nCoV](#); i.e. China, South Korea, Japan, Iran, Hong Kong, Italy, and Taiwan (NB affected countries will change with time, consult the NICD website for current updates);
- OR
- Worked in or attended a healthcare facility where patients with SARS-CoV-2 infections were being treated;
- OR
- Admitted with severe pneumonia of unknown aetiology

A confirmed case: is a person with a laboratory-confirmation of infection with SARS-CoV-2.

A probable case: A PUI for whom testing for SARS-CoV-2 is inconclusive (the result of the test reported by the laboratory) or who tested positive on a pan-coronavirus assay.

A close contact is defined in section 7.3. (contact tracing)

5 Infection control

Ongoing investigations are needed to more fully understand the transmissibility of SARS-CoV-2, but person-to-person spread is occurring and person-to-person and nosocomial transmission was common with MERS-CoV and SARS. The main route of transmission is through contact and respiratory droplets. Airborne transmission has not been proven. The virus is excreted in stool so faeco-oral transmission may be possible. Triage, early recognition and isolation of patients with suspected 2019-nCoV is essential to prevent or limit transmission in healthcare settings.

Based on currently available data, symptomatic cases seem to be the main driver of transmission.

WHO is aware of possible transmission of SARS-CoV-2 from infected people prior to developing

symptoms. Further information is needed to better understand how transmission may have occurred in these few instances. Transmission from an asymptomatic person is very rare with other coronaviruses. Persons who are symptomatic will spread the virus more readily through coughing and sneezing.

- Standard infection-control measures should be applied for all patients with symptoms of acute respiratory infection including:
 - hand and respiratory hygiene
 - use of appropriate personal protective equipment
 - environmental and disinfection procedures should be applied

- For PUI:
 - place a surgical/medical mask over the patients' nose and mouth and evaluate in a private room with the door closed.
 - implement additional contact and droplet precautions
 - use airborne precautions (eg. N95 mask) and eye protection when performing aerosol-generating procedures.
 - if available, airborne precautions should be used at all times.

Healthcare workers are advised to refer to the WHO interim guidance on infection prevention and control during health care for suspected cases of COVID-19. This can be accessed on the WHO website: https://www.who.int/docs/default-source/coronaviruse/20200126-ncov-ipc-during-health-care.pdf?sfvrsn=69e588ce_1&download=true and will be updated as additional information becomes available.

Key contact and droplet precautions include the following:

- isolate the patient (ideally an airborne infection isolation room if available, otherwise adequately ventilated single rooms)
- place patient in a separate room
- healthcare workers to use a medical (surgical/medical) mask and eye (goggles) or facial protection (face shield)
- healthcare workers should wear a clean, non-sterile, long-sleeved gown and use gloves
- healthcare workers should not touch their eyes, nose or mouth with potentially contaminated gloves or bare hands
- limit movement of patient (eg. use designated portable X-ray equipment)
- routinely clean and disinfect surfaces with which the patient is in contact
- limit the number of healthcare workers, family and visitors in contact with suspected or confirmed cases

Additional precautions to be used during aerosol-generating procedures include:

- performing procedures in an adequately ventilated room
- minimising respirator face-seal leakage to fully protect the worker from exposure to aerosolized infectious droplets when using particulate respirators e.g. N95 mask
- eye protection (goggles or face shield) to protect the eyes from respiratory splash or spray
- contact protection (non-sterile, long-sleeved gown and gloves)

Patients with suspected COVID-19 cared for in the home environment

Given the limited knowledge of the disease caused by and transmission of SARS-CoV-2, WHO currently recommends that suspected cases of COVID-19 should be isolated and monitored in a hospital setting. However, under certain circumstances, patients with suspected COVID-19 with mild symptoms and no underlying or immunocompromising conditions may be cared for/isolated in the home environment.

Guidelines to minimise exposure of household contact are available on the WHO website:

[https://www.who.int/publications-detail/home-care-for-patients-with-suspected-novel-coronavirus-\(ncov\)-infection-presenting-with-mild-symptoms-and-management-of-contacts](https://www.who.int/publications-detail/home-care-for-patients-with-suspected-novel-coronavirus-(ncov)-infection-presenting-with-mild-symptoms-and-management-of-contacts)

6 Laboratory diagnosis

6.1 Who should be tested

Only PUI for COVID-19 should be tested. Rapid collection, transport and testing of appropriate specimens from PUI is a priority. Patients should be managed as potentially infected when the clinical and epidemiological data strongly suggest SARS-CoV-2 infection.

Clinical specimens should be collected as soon as possible after onset of symptoms, ideally within 7 days. If patient presents ≥ 7 days from symptom onset and is still symptomatic, respiratory samples, especially lower respiratory samples and a serum sample should still be collected.

6.2 What investigations should be done

- From the moment that COVID-19 is considered as a diagnostic possibility, persons under investigation should be isolated, and infection control measures as described above should be implemented.
- For PUI, appropriate specimens should be collected and transported urgently (same day as collection) for SARS-CoV-2 testing.
- PUI with severe illness should also undergo routinely available laboratory tests as clinically indicated according to local management guidelines for community-acquired pneumonia to determine the presence of other potential primary aetiologies of pneumonia (e.g *Streptococcus pneumoniae*, *Haemophilus influenzae*, *Mycoplasma pneumoniae*, *Legionella pneumophila*, *Mycobacterium tuberculosis* and respiratory viruses including influenza, and respiratory syncytial virus (RSV)). These investigations include at least the following
 - Full blood count
 - Blood cultures
 - Lower respiratory tract specimens
 - Nasopharyngeal swabs or aspirates and oropharyngeal swabs for detection of viral and atypical pathogens
 - Chest radiography
 - Sputum for *Mycobacterium tuberculosis* microscopy and/or molecular detection
- As the role of co-infections is not yet clearly understood, identification of a conventional respiratory pathogen does not rule out SARS-CoV-2 infection.

6.3 Specimen collection and transport

- Infection prevention and control guidelines, including adequate PPE, must be followed during specimen collection, and all specimens handled as potentially infectious.
- **Lower respiratory tract samples are the preferred specimen type because the lower respiratory tract is the primary site of infection** and they are likely to contain the highest viral loads (based on experience with MERS-CoV) and therefore have a better yield. However, collection of all three specimen types (lower respiratory, upper respiratory and serum) for SARS-CoV-2 testing is recommended (Table 1):
 1. Upper respiratory tract specimens - combined nasopharyngeal (NP) and oropharyngeal (OP) swabs in universal transport medium (UTM, or if not available may be sent in gel or dry. Nasopharyngeal swabs must be collected from the nasopharynx and not from the nostril (See appendix 5 on how to collect NP and OP samples). Nasopharyngeal and oropharyngeal swabs should be placed together in the same UTM tube or may be submitted in gel or dry if UTM not available.
 2. Lower respiratory tract specimens (hospitalised/severe cases) – sputum (expectorated or induced), bronchoalveolar lavage, endotracheal aspirate should be submitted in clean universal containers.
 3. Serum - Paired serum samples should be collected; acute (first week of illness) and convalescent (3-4 weeks). Serological testing, in addition to respiratory samples, may support the diagnosis of COVID-19 once serologic tests become available.
- Clinical specimens from suspected or confirmed cases must be shipped to NICD by trained personnel according to the local or international regulations for the transport of dangerous goods (UN3373, Biological Substance Category B infectious substances). See Table 1 for specimen transport conditions. Viral cultures or isolates should be transported as Category A, UN2814, “infectious substance affecting humans”.
- Appendix 6 describes detailed procedures for submission of specimens (local and international) to NICD for persons under investigation
- **A completed specimen submission form (Appendix 7) must be submitted to the laboratory together with specimens for SARS-CoV-2 testing.**

Table 1 lists the type of specimens that can be collected for testing for SARS-CoV-2.

Table 1. Type of specimens that can be collected for SARS-CoV-2/COVID-19 diagnostics and the transport requirements of these specimens

Specimen type	Collection materials	Storage and transportation	Dangerous goods shipping category	Comment
FOR SYMPTOMATIC PATIENTS:				
Sputum*	Deep cough sputum in sterile leak proof container	Refrigerate and ship at 2-8 °C up to 48 hrs, if >48 hrs freeze at -70°C and ship on dry ice	Biological substance, Category B	The preferred sample but need to ensure the material is from the lower respiratory tract

Bronchoalveolar lavage*	2-3 ml in sterile leak proof container	Refrigerate and ship at 2-8 °C up to 48 hrs, if >48 hrs freeze at -70°C and ship on dry ice	Biological substance, Category B	There may be some dilution of virus but still a worthwhile specimen
(Endo)tracheal or nasopharyngeal aspirate*	2-3 ml in sterile leak proof container	Refrigerate and ship at 2-8 °C up to 48 hrs, if >48 hrs freeze at -70°C and ship on dry ice	Biological substance, Category B	
Nasopharyngeal and oropharyngeal swab	Dacron or nylon flocced swab in Universal Transport Medium (UTM) or gel (or dry if neither available) in a sterile leak proof container	Refrigerate at 2-8 °C up to 5 days, if >5 days freeze at -70°C and ship on dry ice	Biological substance, Category B	Nasopharyngeal and oropharyngeal swabs should be placed in the same tube to increase the viral load
Serum	Serum separator tube**	Store upright for at least 30 minutes after collection. a Refrigerate and ship at 2-8 °C within 5 days	Biological substance, Category B	Collect paired samples: <ul style="list-style-type: none"> • Acute – first week of illness • Convalescent – 3-4 weeks later
Lung tissue from biopsy or autopsy	Sterile container with saline	Refrigerate and ship at 2-8 °C up to 24 hrs, if >24 hrs freeze at -70°C and ship on dry ice		

* Aerosol-generating procedures may pose an infection risk for health care workers. ** Children and adults: collect 1 tube (5-10 ml) of whole blood in a serum separator tube. Infant: a minimum of 1 ml in a serum separator tube.

6.4 Laboratory diagnostic assays and interpretation of results

Routine confirmation of cases of COVID-19 is based on amplification and detection of unique SARS-CoV-2 viral nucleic acid sequences by real-time reverse-transcription polymerase chain reaction (rRT-PCR), with confirmation by nucleic acid sequencing when necessary.⁷

Currently, the NICD offers testing for SARS-CoV-2 using the Charite Institute rRT-PCR assay. The protocol for testing is based on a method described by Corman *et al*, 2020.⁸ Testing for SARS-CoV-2 must be performed in appropriately equipped laboratories by staff trained in the relevant technical and safety procedures. Initial processing of specimens (before inactivation) should be done in a biological safety cabinet. Molecular testing should be conducted in aBSL-2 laboratory. Viral culture and isolation should only be performed by properly trained and competent personnel in a BSL-3 laboratory. Appropriate PPE must be worn by all laboratory personnel handling SARS-CoV-2 specimens.

A negative result does not rule out the possibility of a SARS-CoV-2 infection. A number of factors could lead to a false –negative result including:

- Poor specimen quality
- The specimen was collected late or very early in the illness
- The specimen was not handled and shipped appropriately, e.g the cold chain of specimens was not properly maintained throughout the process i.e from the point of collection up until receipt and processing
- Technical reasons inherent in the test, e.g virus mutation or PCR inhibition.

⁷ World Health Organization. Laboratory testing for 2019 novel coronavirus (2019-nCoV) in suspected human cases Interim guidance 14 January 2020 [cited 30 January 2020] https://www.who.int/docs/default-source/coronaviruse/20200114-interim-laboratory-guidance-version.pdf?sfvrsn=6967c39b_4&download=true

⁸ Corman, V. et al., Detection of 2019 novel coronavirus (2019-nCoV) by real-time RT-PCR. Euro Surveill. 2020;25(3):pii=2000045. <https://doi.org/10.2807/1560-7917.ES.2020.25.3.2000045>

If negative results are obtained from patients with a high index of suspicion for SARS-CoV-2 infection, especially when only upper respiratory tract samples were collected, additional specimens, including lower respiratory samples should be collected and tested.

Figure 1 illustrates the laboratory algorithm followed for testing of specimens collected from a suspected COVID-19 case.

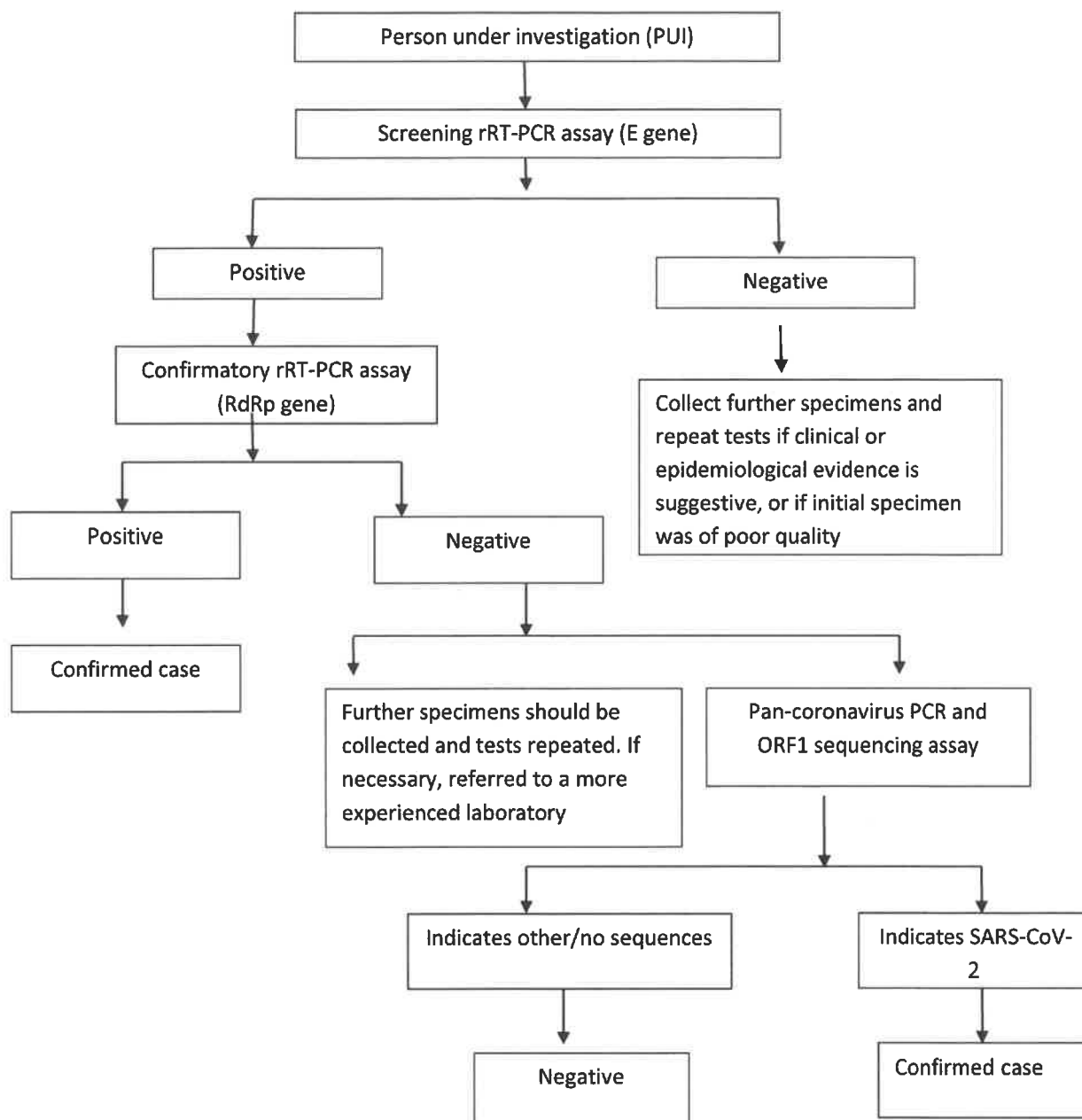

Figure 1: Algorithm for testing persons under investigation for SARS-CoV-2 by rRT-PCR and sequencing

The laboratory turnaround time (TAT) for SARS-CoV-2 testing is 24 hours from time of specimen receipt in the NICD laboratory. Where possible, a specimen that tests positive for SARS-CoV-2 will be further characterised by viral culture and whole genome sequencing.

7 Public health response

The detection of a case of COVID-19 constitutes a public health emergency and a risk to the safety of the patient, their contacts including health care workers, and more broadly, the wellbeing of the South African community. Even at the time the decision is made to test a patient for COVID-19, consideration must be made of the public health response.

The South African National Department of Health, the NICD and provincial health departments have structures for responding to outbreaks of communicable diseases, and these have been activated to assist with preparedness activities.

7.1 Response to a suspected case

See flow diagram in appendix 1, 2 and 4 for management of PUI.

7.2 Response to a confirmed case

- Any person who has had close contact with a confirmed case while the confirmed case was ill or in the 7 days preceding illness onset should be carefully monitored (at home) for the appearance of respiratory symptoms.
- If symptoms develop within the first 14 days following the contact, the individual should be considered a PUI regardless of the severity of illness and investigated accordingly.
- Close contacts who are ill and do not require hospitalisation for medical reasons may be cared for and isolated in their home while being evaluated for SARS-CoV-2 infection. (Isolation is defined as the separation or restriction of activities of an ill person with a contagious disease from those who are well).

7.3 Contact tracing

- A flow diagram for contact tracing is in Appendix 3. A contact line list (Appendix 9) should be completed for each person under investigation at time of sample collection and completion of the investigation form by the facility infection control focal point, attending clinician or designated port health officer. If the form cannot be completed at this time, the district or provincial CDC will complete the form when notified of the case. A copy of this form should be submitted to ncov@nicd.ac.za.
- Details of close contacts from the day of symptom onset will be collected on the contact line list.
- A close contact is defined as:
 - A person having had face-to-face contact (≤ 2 metres) or was in a closed environment with a COVID-19 case; this includes, amongst others, all persons living in the same household as a COVID-19 case and, people working closely in the same environment as a case,
 - A healthcare worker or other person providing direct care for a COVID-19 case while not wearing recommended personal protective equipment or PPE (e.g., gowns, gloves, NIOSH-certified disposable N95 respirator, eye protection),
 - A contact in an aircraft sitting within two seats (in any direction) of the COVID-19 case, travel companions or persons providing care, and crew members serving in the section of the aircraft where the index case was seated [1] (if severity of symptoms or movement of the case indicate more extensive exposure, passengers seated in

the entire section or all passengers on the aircraft may be considered close contacts).

- If laboratory testing confirms SARS-CoV-2 infection, the provincial CDCC will be requested to use the contact line list to call each contact to complete the contact demographic section on the contact monitoring form. Once details are completed, forms are to be emailed to ncov@nicd.ac.za
- Forms will be captured on the COVID-19 contact database at NICD.
- A thermometer will be issued to each contact if they do not have one. Close contacts will be asked to self-quarantine themselves at home for 14 days since last exposure to the confirmed COVID-19 case.
- Close contacts will be monitored telephonically by the NICD call centre personnel for 14 days post last exposure to the confirmed case using the symptom monitoring tool (Appendix 10) and captured directly to the database. If at any point during the monitoring period the contact becomes unreachable for more than 24 hours, the provincial CDCC team will do a home visit. For contacts who are not able to perform daily temperature measurements at home, daily home visits will be conducted by provincial CDCC team.
- Monitoring of close contacts may switch from telephonic monitoring to self-monitoring dependant on the number of contacts to be followed up.
- Close contacts under monitoring should be advised to:
 - Remain at home (CDCC /NICD will provide an official letter for employment or education facilities)
 - Avoid unnecessary social contact
 - Avoid travel
 - Remain reachable for monitoring
- Should a contact develop symptoms, the provincial CDCC should be informed by NICD. Arrangements will be made by CDCC for a health care worker to visit the patient in their home on the same day to collect a specimen and to complete the required documentation. Appropriate PPE should be used (e.g., gowns, gloves, surgical mask or NIOSH-certified disposable N95 respirator, eye protection). If a healthcare worker is not available, the patient will be requested to visit their nearest healthcare facility to have a specimen collected.
- The CDCC should inform the healthcare facility of the incoming patient in order for the healthcare facility to use appropriate infection prevention and control (IPC) measures.
- Monitoring of close contacts may switch from telephonic monitoring to self-monitoring dependant on the number of contacts to be followed up.
- Individuals not meeting the definition of a close contact but with possible exposure should be informed to contact their healthcare practitioner if any symptoms develop within 14 days since exposure to the confirmed COVID-19 case.

Healthcare workers with occupational exposure

- Lists of healthcare workers with occupation exposure should be compiled by the health facility
- They should be actively monitored for symptoms and rapidly isolated and tested should symptoms develop

7.3.1 Data management

All contact line lists and symptom monitoring forms with completed demographic information should be forwarded to ncov@nicd.ac.za for capturing at NICD. Symptom monitoring should be captured directly to database, by NICD call-centre personnel.

7.4 Management of the deceased

- All attempts should be made to confirm the diagnosis in persons who are close contacts who die. Post mortem nasopharyngeal swabs, and if possible, bronchial washings may be taken. Contact and droplet precautions should be used.

7.5 Quarantine

Quarantine entails separating **asymptomatic** individuals potentially exposed to a disease from non-exposed individuals. Quarantine is to be distinguished from isolation, which is the act of separating a **sick** individual with a contagious disease from healthy individuals without that contagious disease. Quarantine procedures can be effective in limiting and slowing the introduction of a novel pathogen into a population, but may entail the use of considerable resources and may infringe on the rights of members of society. Quarantine may be voluntary (e.g. asking contacts of infectious cases to stay at home for 14 days) or involuntary (i.e. using legal powers to enforce quarantine against a person's will). Quarantine may take place in the home (e.g. asking contacts of infectious cases to stay at home for 14 days) or in a designated facility. Depending on level of risk of the exposure different levels of quarantine will be employed, for an example if a person comes back from Wuhan, voluntary quarantine at home will be recommended. Whereas, if health worker not wearing appropriate PEP is exposed to a confirmed case, the health worker would be allowed to work and self-quarantine after hours. Quarantine may be applied at the individual level or to a group or community of exposed persons. Asymptomatic contacts will be voluntarily quarantined at home.

8 Additional Resources

- NICD website on 2019-nCoV: <http://www.nicd.ac.za/diseases-a-z-index/covid-19/>
- Daily WHO situation update: <https://www.who.int/emergencies/diseases/novel-coronavirus-2019/situation-reports/>
- The WHO interim clinical care guidance: <https://www.who.int/emergencies/diseases/novel-coronavirus-2019/technical-guidance>.
- WHO interim guidance on infection prevention and control during health care for suspected cases of 2019-nCoV: https://www.who.int/docs/default-source/coronaviruse/20200126-ncov-ipc-during-health-care.pdf?sfvrsn=69e588ce_1&download=true
- WHO guidelines to minimise exposure of household contact: [https://www.who.int/publications-detail/home-care-for-patients-with-suspected-novel-coronavirus-\(ncov\)-infection-presenting-with-mild-symptoms-and-management-of-contacts](https://www.who.int/publications-detail/home-care-for-patients-with-suspected-novel-coronavirus-(ncov)-infection-presenting-with-mild-symptoms-and-management-of-contacts)
- WHO Coronavirus Information Page: <https://www.who.int/emergencies/diseases/novel-coronavirus-2019>
- Centers for Disease Control and Prevention (CDC), <https://www.cdc.gov/coronavirus/2019-ncov/index.html>

9 Appendices

9.1 Appendix 1 – process flow for detection and response to cases

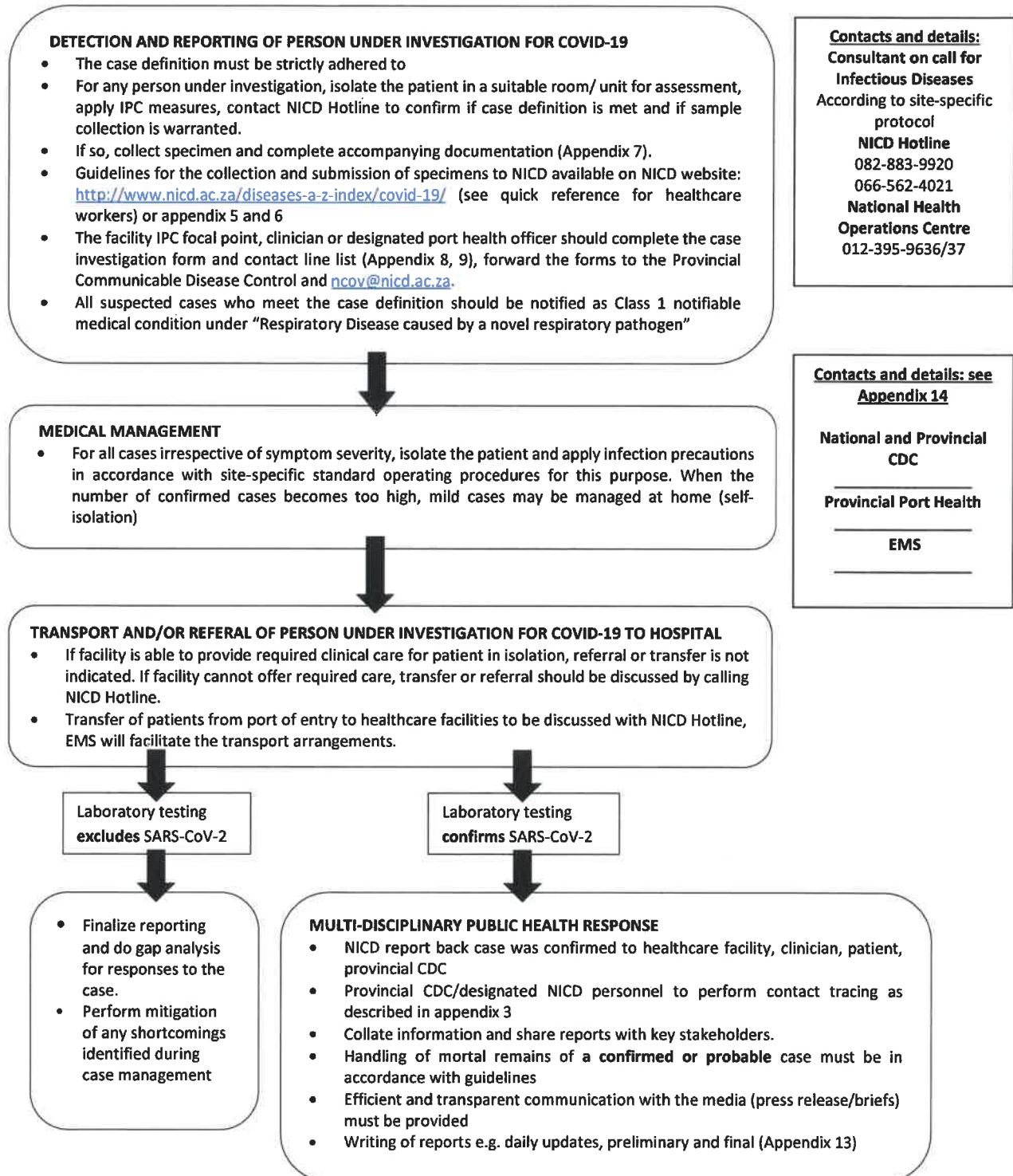

9.2 Appendix 2 – roles and responsibilities of facility, district, province and national vis a vis information flow

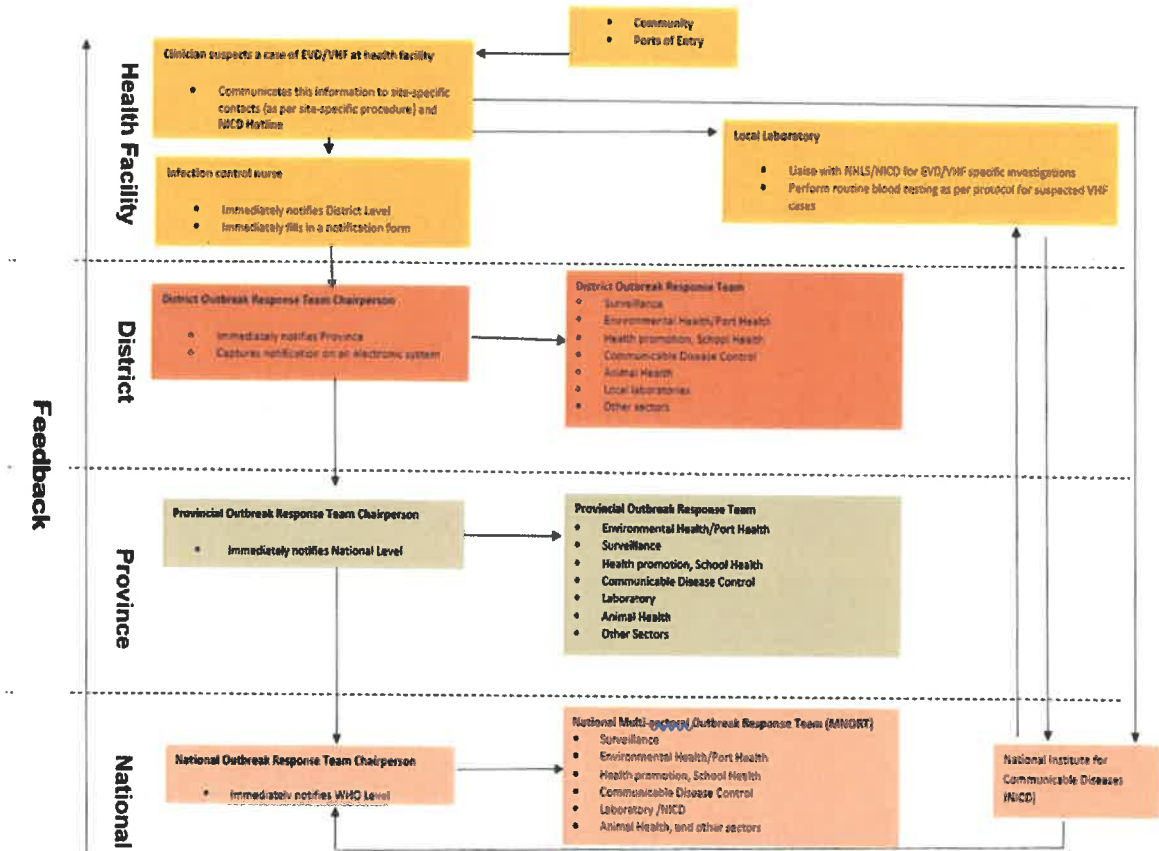

9.3 Appendix 3 – flow diagram for contact tracing, screening and monitoring

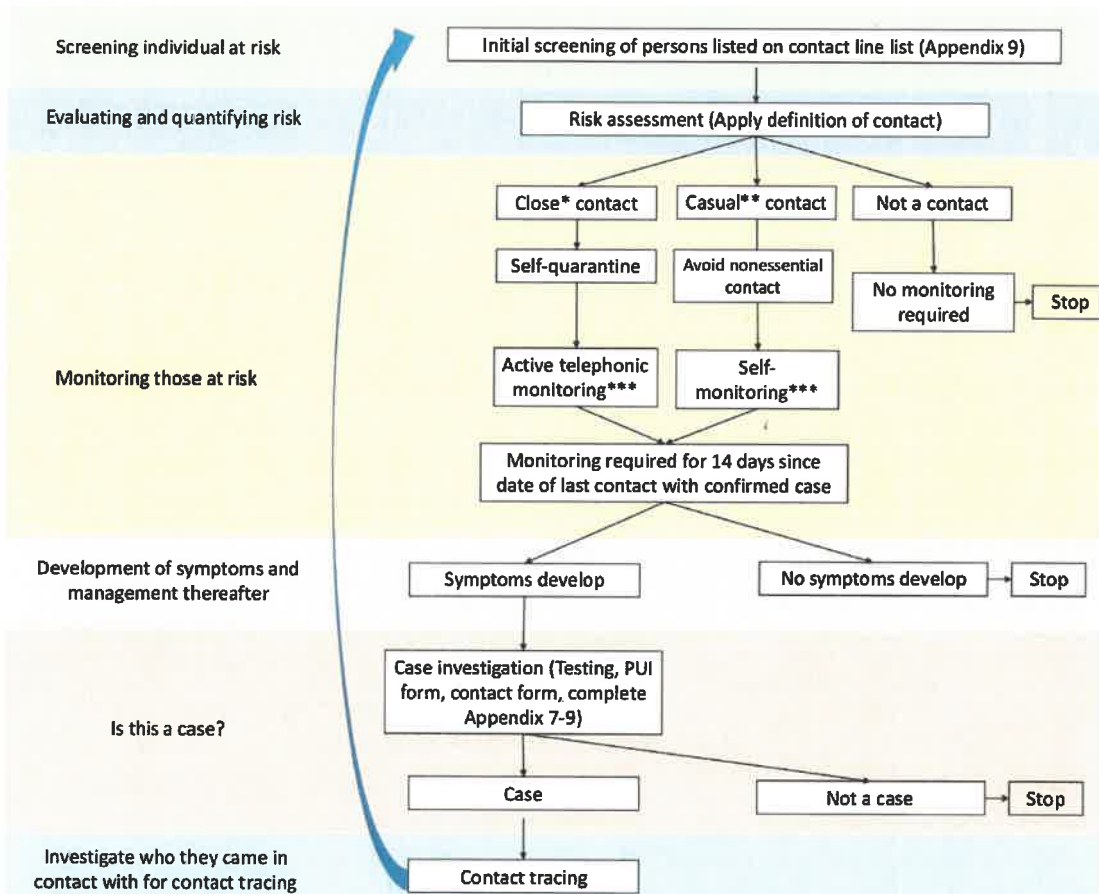

* Close contact: A person having had face-to-face contact (≤2 metres) or was in a closed environment with a COVID-19 case; this includes, amongst others, all persons living in the same household as a COVID-19 case and, people working closely in the same environment as a case. A healthcare worker or other person providing direct care for a COVID-19 case, while not wearing recommended personal protective equipment or PPE (e.g., gowns, gloves, NIOSH-certified disposable N95 respirator, eye protection). A contact in an aircraft sitting within two seats (in any direction) of the COVID-19 case, travel companions or persons providing care, and crew members serving in the section of the aircraft where the index case was seated.
 ** Casual contact: Anyone not meeting the definition for a close contact but with possible exposure.
 *** Monitoring methods: Active-telephonic monitoring: NICD call centre will phone person who is home-quarantined each day for a symptom report; Self-monitoring: person to consult healthcare practitioner in the event of symptom development.

9.4 Appendix 4 – Initial diagnosis and management of suspected case, including infection control measures

Coronavirus disease 2019 (COVID-19) process flow for use in healthcare facilities

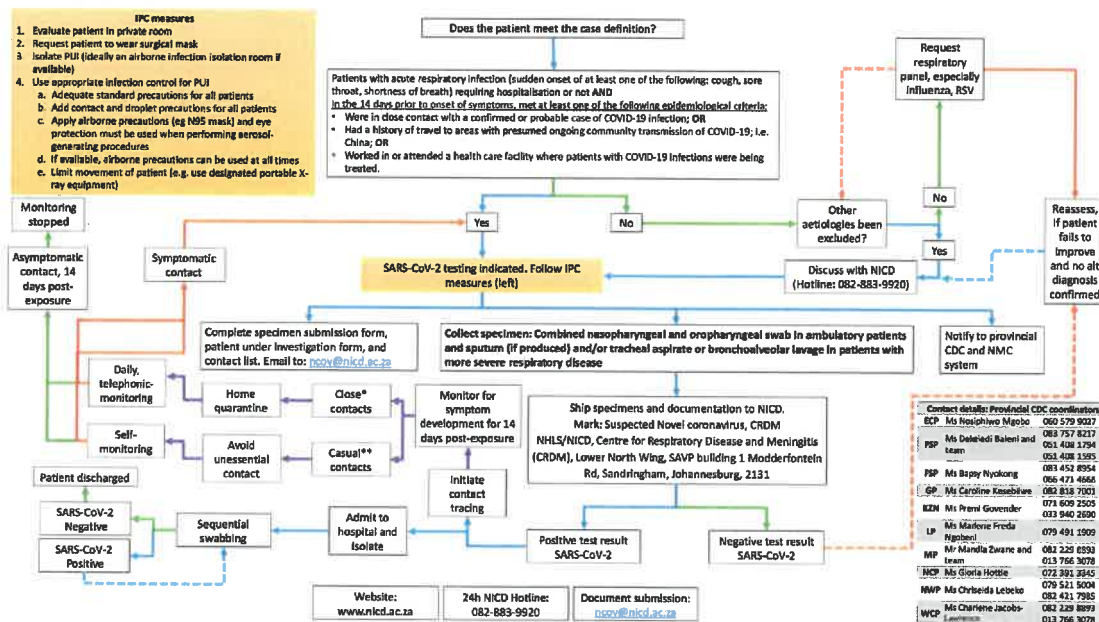

* Close contact: A person having had face-to-face contact (≤2 metres) or was in a closed environment with a COVID-19 case; this includes, amongst others, all persons living in the same household as a COVID-19 case and, people working closely in the same environment as a case. A healthcare worker or other person providing direct care for a COVID-19 case, while not wearing recommended personal protective equipment or PPE (e.g., gowns, gloves, NIOSH-certified disposable N95 respirator eye protection). A contact in an aircraft sitting within two seats (in any direction) of the COVID-19 case, travel companions or persons providing care, and crew members serving in the section of the aircraft where the index case was seated.
** Casual contact: Anyone not meeting the definition for a close contact but with possible exposure.

9.5 Appendix 5: Collection of nasopharyngeal and oropharyngeal swab and nasopharyngeal aspirate

Type of swabs

Only nylon or rayon flocked nasopharyngeal and oropharyngeal swabs with perforated, flexible plastic shaft must be used for collection of specimens. There is evidence to suggest some benefit to using flocked swabs for recovery of pathogens over other types. An appropriate size of the nasopharyngeal swab should be used, paediatric swab for children and adult swab for older children and adults. Cotton-tipped, calcium alginate swabs or swabs with wooden shafts should not be used as residues present in these materials may inhibit PCR assays.

Collecting the nasopharyngeal swab

- Gently insert nasopharyngeal flocked swab into the nostril aiming backwards, along the floor of the nasal cavity, until the nasopharynx is reached. Be careful not to insert swab upwards. If resistance is encountered during insertion of the swab, remove it and try the other nostril. The distance from the nose to the ear gives an estimate of the distance the swab should be inserted
- Gently rotate the swab and hold in place for a few seconds
- Slowly withdraw swab
- Unscrew and remove the cap from the tube with transport medium.
- Insert the swab directly into a vial containing universal transport medium (UTM)
- Break plastic shaft at the break point so that it can fit in the universal transport medium tube
- Close the tube with the lid
- Refrigerate at 2-8 °C

Collecting oropharyngeal swab (OPS)

- Keeping the same pair of gloves on, and holding the UTM with the nasopharyngeal swab in, take a second flocked swab and open it at the plastic shaft
- Ask the patient to tilt their head back and open mouth wide
- Hold the tongue down with a tongue depressor
- Have the patient say “aahh” to elevate the uvula
- Swab each tonsil first, then the posterior pharynx in a “figure 8” movement
- Avoid swabbing the soft palate and do not touch the tongue with the swab tip as this procedure can induce the gag reflex.
- Insert the swab directly into the same UTM vial containing the nasopharyngeal swab
- Break plastic shaft at the break point so that it can fit in the universal transport medium tube
- Close the tube with the lid
- Refrigerate at 2-8 °C

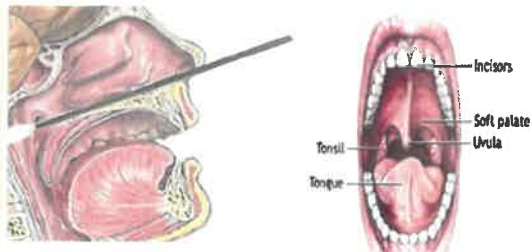

Figure 1: How to collect a nasopharyngeal swab (left) and oropharyngeal swab (right)

Nasopharyngeal aspirates

- Fill syringe with 2-3 ml saline; attach catheter tubing to syringe tip
- Slowly insert the catheter into one nostril until the pharyngeal wall is reached
- Quickly inject saline into nostril and then aspirate the recoverable nasopharyngeal specimen
- Withdraw the catheter under suction, being careful not to touch the tip
- Inject the aspirated fluid into a labelled sterile specimen container/ universal transport medium
- Refrigerate at 2-8 °C



Figure 2: Flocked swab and Universal Transport Medium

9.6 Appendix 6. Procedures for submission of specimens for investigation

Step 1: Report the PUI to the NICD to allow a risk assessment to be carried out and guide laboratory testing

- Contact the NICD Hotline +27 82 883 9920
- The test will be free of charge for patients meeting the case definitions above

Step 2: Complete the person under investigation form and specimen submission form

- Fully complete the person under investigation form <http://www.nicd.ac.za/diseases-a-z-index/novel-coronavirus-infection/>
- Fully complete the specimen submission form for each specimen submitted for testing <http://www.nicd.ac.za/diseases-a-z-index/novel-coronavirus-infection/>. For the "Test requested" section, select "Other" and specify "Novel coronavirus" or "SARS-CoV-2".

Step 3: Submit specimens for specialized laboratory investigation

- Each specimen should be clearly labelled with the patient name, date of birth and sample type.
- The specimens should be stored and shipped at 2-8°C (cooler box with ice packs). Specimens should be packaged in accordance with the guidelines for the transport of biological goods and transported directly and urgently.
- Transport specimens to NICD on same day as specimen collection.
- Please mark for attention of:

**Suspected novel coronavirus (COVID-19) CRDM
NHLS/NICD
Centre for Respiratory Disease and Meningitis (CRDM)
Lower North Wing, SAVP building
1 Modderfontein Rd, Sandringham, Johannesburg, 2131
South Africa**

- Please notify by email the CRDM staff below of any pending shipments:
 - Linda de Gouveia lindad@nicd.ac.za (011-555-0327) or
 - Amelia Buys ameliab@nicd.ac.za (011-386-6373) or
 - Cardia Fourie cardiaf@nicd.ac.za (011-386-6373)
- Ensure that the completed (i) specimen submission form and (ii) person under investigation form accompanies the specimens
- Avoid repeated freezing and thawing of specimens
- **Packaging and transport of samples to NICD**

Samples referred from local (same province) or national (different province) NHLS and private laboratories to NICD

- Laboratories should follow their local guidelines/transport SOPs for sample packaging and make use of usual overnight regional courier services to ship samples to NICD.
- Contact CRDM for assistance if transport system is not available
- Patient specimens from suspected for confirmed COVID-19 cases should be transported as Biological Substance Category B.
- For local and national shipments, specimens should be placed in a secondary container (Ziploc bag), to minimise potential for spill, and transported in a clearly marked cooler box with ice packs.

International transport of clinical samples from suspected or confirmed cases:

The parcel should bear the appropriate outer warnings that it contains biohazardous material.

If transported by air, IATA regulations (UN3373, Biological Substance, Category B) must be followed and appropriate labelling applied (refer to www.iata.org). In addition to completing an ordinary air waybill for parcels sent by air, it is necessary to complete a shipper's declaration for dangerous goods (refer to www.iata.org or your courier company). The principle of triple layer packaging and IATA regulations must be followed (Figure 1). UN/WHO approved shipping containers for hazardous specimens are commercially available, e.g. SAF-T-PAK® (www.saftpak.com) or PATHOPAK® (www.intelsius.com).

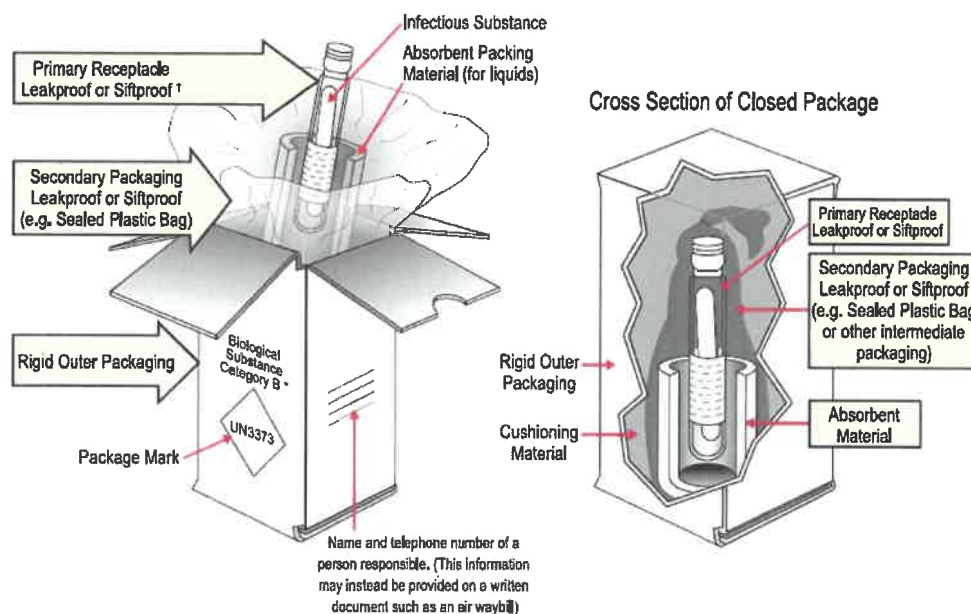

Figure 1. Example of the triple packaging system for the packing and labelling of Category B Biological substances for international shipment of clinical specimens.

It is required that designated staff members per site are trained by approved provider in the packaging and transport of dangerous goods. The IATA of WHO websites may be consulted for international regulations and guidelines in this regard. Primary specimen containers (properly labelled) should be wrapped in sufficient absorbent material (paper towels or tissues) to absorb the entire contents in the event of leakage. The wrapped primary containers must be placed in durable, leak-proof secondary containers such as several layers of sealed plastic bags or, preferably, rigid screw-cap metal, plastic or similar containers (suitable containers are usually available from hospital dispensaries). The secondary container should be taped closed to prevent leakage. The secondary containers and data forms, sealed separately in plastic, must then be placed in a rigid outer (tertiary) container such as a fibre carton or polystyrene cold box with cold packs. The outer wrapping should be addressed to:

**NHLS/NICD
Centre for Respiratory Disease and Meningitis (CRDM)
Lower North Wing, SAVP building
1 Modderfontein Rd, Sandringham, Johannesburg, 2131
South Africa**

9.7 Appendix 7 - Specimen submission form

The pdf can be downloaded at <http://www.nicd.ac.za/diseases-a-z-index/covid-19/>

CRDM unique no:	CRDM lab no:	Trak no:	Date received:
Centre for Respiratory Diseases and Meningitis Specimen Submission form			
Patient Information		Submitter Information (contact person for results)	
Identifier or Hospital no		Surname	
Surname		First name	
First name		Laboratory	
Age/Date of birth		City, Country	
Gender		Contact number (South Africa) + ()	
Facility/Hospital		Email address	
Specimen Details			
Specimen collection date:			
Specimen type:	<input type="checkbox"/> Combined NP/OP swab <input type="checkbox"/> Nasopharyngeal (NP) aspirate <input type="checkbox"/> Nasal swab <input type="checkbox"/> Nasopharyngeal (NP) swab <input type="checkbox"/> Bronchoalveolar lavage (BAL) <input type="checkbox"/> Sputum <input type="checkbox"/> Oropharyngeal (OP) swab <input type="checkbox"/> Pleural fluid <input type="checkbox"/> CSF <input type="checkbox"/> Tracheal aspirate (TA) <input type="checkbox"/> Blood culture <input type="checkbox"/> Serum <input type="checkbox"/> Whole blood <input type="checkbox"/> Other, specify: _____		
Laboratory Test Details (please consult with CRDM if testing other than influenza, RSV or B. pertussis is required)			
Tests requested:	<input type="checkbox"/> Avian influenza <input type="checkbox"/> Influenza / RSV <input type="checkbox"/> MERS-CoV <input type="checkbox"/> Neonatal sepsis* <input type="checkbox"/> <i>Bordetella pertussis</i> <input type="checkbox"/> <i>Legionella</i> spp. <input type="checkbox"/> Atypical pneumonia* <input type="checkbox"/> Bacterial meningitis* <small>* Refer to page 2 for test panel details</small> <input type="checkbox"/> <i>C. diphtheriae</i> <input type="checkbox"/> Respiratory panel (bacterial & viral)* <input type="checkbox"/> Viral meningitis* <input type="checkbox"/> Group A streptococcus <input type="checkbox"/> Community-acquired pneumonia (bacteria)* <input type="checkbox"/> SARS-CoV-2 <input type="checkbox"/> Group B streptococcus <input type="checkbox"/> Hospital-acquired pneumonia (bacteria)* <input type="checkbox"/> Other, specify: _____		
Clinical Presentation and Outcome		Date of symptom onset:	
Clinical diagnosis:	<input type="checkbox"/> Acute rheumatic fever <input type="checkbox"/> Meningococcal disease <input type="checkbox"/> Lower respiratory tract infection <input type="checkbox"/> Diphtheria <input type="checkbox"/> Influenza-like illness <input type="checkbox"/> Upper respiratory tract infection <input type="checkbox"/> Pertussis <input type="checkbox"/> Meningitis <input type="checkbox"/> Other, specify: _____		
Symptoms:	<input type="checkbox"/> Fever ($\geq 38^{\circ}\text{C}$) <input type="checkbox"/> Sore Throat <input type="checkbox"/> Cough <input type="checkbox"/> Headache <input type="checkbox"/> Stiff neck <input type="checkbox"/> Shortness of breath <input type="checkbox"/> Vomiting <input type="checkbox"/> Diarrhoea <input type="checkbox"/> Paroxysmal cough/inspiratory whoop <input type="checkbox"/> Apnoea <input type="checkbox"/> Other, specify: _____ <input type="checkbox"/> Unknown <input type="checkbox"/> None		
Underlying Risk Factors:	<input type="checkbox"/> Asthma <input type="checkbox"/> Chronic Lung Disease <input type="checkbox"/> Diabetes <input type="checkbox"/> HIV <input type="checkbox"/> Pregnancy <input type="checkbox"/> TB <input type="checkbox"/> Heart Disease <input type="checkbox"/> Other, specify: _____ <input type="checkbox"/> Unknown <input type="checkbox"/> None		
Hospitalisation:	<input type="checkbox"/> Outpatient <input type="checkbox"/> Inpatient— not admitted ICU <input type="checkbox"/> Inpatient— admitted to ICU <input type="checkbox"/> Unknown Outcome: <input type="checkbox"/> Still hospitalised <input type="checkbox"/> Survived <input type="checkbox"/> Died <input type="checkbox"/> Unknown		
Exposure History			
Did the patient travel in the 14 days prior to symptom onset? <input type="checkbox"/> Yes <input type="checkbox"/> No <input type="checkbox"/> Unknown			
Area/Country travelled to:		Date of travel to this area	Date of travel from this area
1.			
2.			
Did the patient have animal contact in the 14 days prior to symptom onset? <input type="checkbox"/> Yes <input type="checkbox"/> No <input type="checkbox"/> Unknown			
Animal type		Date of exposure	Exposure type
<input type="checkbox"/> Swine <input type="checkbox"/> Wildbirds <input type="checkbox"/> Poultry (eg. chickens, ostrich, ducks)			
Other, specify: _____			
Tel: +27 (0)11 555 0315 0317 NICD Hotline: 082 883 9920 Email: lndad@nicd.ac.za/orienkah@nicd.ac.za Please attach any relevant information			

9.8 Appendix 8– Person under investigation form

PDF version at: <http://www.nicd.ac.za/diseases-a-z-index/covid-19/>

Person under investigation (PUI) form for coronavirus disease 2019 (COVID-19):
 Request for severe acute respiratory syndrome coronavirus 2 (SARS-CoV-2) testing

Internal use
 CRDM unique no: _____

Tel: (+27) 386 6392/ (+27) 386 6410 | Fax: (+27)11 882 9979 | Hotline: (+27)82 883 9920 | (+27)66 562 4021

Forward original forms with the specimen collected.

Email completed specimen submission form and PUI form to ncov@nicd.ac.za

Today's date: _____

Form completed by (Name, Surname): _____ Contact number(s): _____

All suspected COVID-19 cases are Category 1 **notifiable medical conditions** under "Respiratory disease caused by a novel respiratory pathogen". Notify as per NMC procedures. If using NMC app provide case ID indicated on alert email.

Case ID : _____

Is this a:
 New clinical query
 Contact of a known case
 If contact of a known case, provide case details: _____

Known case first name: _____

Known case surname: _____

Known case DOB: DD/MM/YYYY _____

Detected at point of entry? Y N Unkn If yes, date: DD/MM/YYYY: _____ Please specify the point of entry: _____

PATIENT DETAILS		DOCTOR'S DETAILS	
Patient hospital number (if available): _____		First name: _____	
First name: _____	Surname: _____	Surname: _____	
DOB: DD/MM/YYYY _____	Sex: Male <input type="checkbox"/> Female <input type="checkbox"/>	Facility name: _____	
Residency: SA resident <input type="checkbox"/> Non-SA resident <input type="checkbox"/> Specify: _____		Contact number/s: _____	
Current residential address: _____		Email address: _____	
Patient's contact number(s): _____ <i>Include alternative number</i>			
Please indicate occupation (tick all that apply):			
Student <input type="checkbox"/>	Unemployed <input type="checkbox"/>		
Working with animals <input type="checkbox"/>	Health laboratory worker <input type="checkbox"/>		
Healthcare worker <input type="checkbox"/>	Facility name: _____		
Other <input type="checkbox"/>	Specify: _____		

NEXT OF KIN CONTACT DETAILS (alternative contact details)

First name: _____ Surname: _____

Relationship to the patient: _____ Contact number(s): _____

CLINICAL PRESENTATION AND HISTORY

Date of symptom onset: DD/MM/YYYY _____ Date of current consultation/admission: DD/MM/YYYY _____

Fever (≥38°C) <input type="checkbox"/> Y <input type="checkbox"/> N	Sore throat <input type="checkbox"/> Y <input type="checkbox"/> N	Myalgia/body pains <input type="checkbox"/> Y <input type="checkbox"/> N
History of fever <input type="checkbox"/> Y <input type="checkbox"/> N	Shortness of breath <input type="checkbox"/> Y <input type="checkbox"/> N	General weakness <input type="checkbox"/> Y <input type="checkbox"/> N
Cough <input type="checkbox"/> Y <input type="checkbox"/> N	Nausea/vomiting <input type="checkbox"/> Y <input type="checkbox"/> N	Irritability/confusion <input type="checkbox"/> Y <input type="checkbox"/> N
Chills <input type="checkbox"/> Y <input type="checkbox"/> N	Diarrhoea <input type="checkbox"/> Y <input type="checkbox"/> N	Other <input type="checkbox"/> Y <input type="checkbox"/> N Specify: _____

DIAGNOSIS

- Did the patient have clinical or radiological evidence of pneumonia Y N
- Were chest X-rays (CXR) done: Y N If yes, CXR Findings: _____
- Did the patient have clinical or radiological evidence of acute respiratory distress syndrome (ARDS)? Y N

This section is a prerequisite for testing, therefore, please fill out the below section to the best of your ability. **Laboratory testing will be delayed if forms are incomplete or were filled in incorrectly.**
In the 14 days before symptom onset did the patient (mark all that apply):

- Have close physical contact² with a known COVID-19 case? Y N Unkn
- If the patient has been in a close physical contact with a known COVID-19 case, please indicate contact setting:
 Healthcare setting Family setting Work place Public transport setting Other Specify: _____
- Patient is a healthcare worker (HCW) who was exposed to patients with severe acute respiratory illness, unless another aetiology has been identified to explain the clinical presentation of the HCW? Y N Unkn
- Is the patient part of a severe respiratory illness cluster of unknown aetiology that occurred within a 14-day period? Y N Unkn
- Patient has visited a health care facility (as a patient or visitor) in a country where hospital-associated COVID-19 cases have been reported? Y N Unkn (if yes, complete travel section)
- Has the patient travelled to/from China or area/s with evidence of sustained SARS-CoV-2 (cause of COVID-19) human-to-human transmission, or a declared outbreak? Y N Unkn (if yes, complete travel section)

TRAVEL HISTORY

If patient traveled outside South Africa in the last 14-days, please complete section below for countries visited

Country and city or cities visited	Date of departure (travel to area)	Date of return (travel from area)
1. _____	DD/MM/YYYY	DD/MM/YYYY
2. _____	DD/MM/YYYY	DD/MM/YYYY

UNDERLYING FACTORS/CO-MORBID CONDITIONS

Asthma:	Y <input type="checkbox"/> N <input type="checkbox"/> Unkn <input type="checkbox"/>	Cardiac disease:	Y <input type="checkbox"/> N <input type="checkbox"/> Unkn <input type="checkbox"/>	Chronic kidney disease:	Y <input type="checkbox"/> N <input type="checkbox"/> Unkn <input type="checkbox"/>	Chronic liver disease:	Y <input type="checkbox"/> N <input type="checkbox"/> Unkn <input type="checkbox"/>
Chronic neurological/neuromuscular disease:	Y <input type="checkbox"/> N <input type="checkbox"/> Unkn <input type="checkbox"/>	COPD/ Chronic pulmonary disease:	Y <input type="checkbox"/> N <input type="checkbox"/> Unkn <input type="checkbox"/>	Diabetes:	Y <input type="checkbox"/> N <input type="checkbox"/> Unkn <input type="checkbox"/>	Immuno-deficiency (excluding HIV)	Y <input type="checkbox"/> N <input type="checkbox"/> Unkn <input type="checkbox"/>
HIV:	Y <input type="checkbox"/> N <input type="checkbox"/> Unkn <input type="checkbox"/>	Is the patient virally suppressed?	Y <input type="checkbox"/> N <input type="checkbox"/> Unkn <input type="checkbox"/>	Recent viral load:	_____	On ARVs	Y <input type="checkbox"/> N <input type="checkbox"/> Unkn <input type="checkbox"/>
Obesity:	Y <input type="checkbox"/> N <input type="checkbox"/> Unkn <input type="checkbox"/>	Pregnancy:	Y <input type="checkbox"/> N <input type="checkbox"/> Unkn <input type="checkbox"/>	Trimester:	_____	Tuberculosis:	Y <input type="checkbox"/> N <input type="checkbox"/> Unkn <input type="checkbox"/>
Other:	Y <input type="checkbox"/> N <input type="checkbox"/> Unkn <input type="checkbox"/>	Specify:	_____				

TREATMENT/MANAGEMENT

Patient hospitalised:	Y <input type="checkbox"/> N <input type="checkbox"/> Unkn <input type="checkbox"/>	Admitted to ICU:	Y <input type="checkbox"/> N <input type="checkbox"/> Unkn <input type="checkbox"/>	Ventilation:	Y <input type="checkbox"/> N <input type="checkbox"/> Unkn <input type="checkbox"/>	On ECMO:	Y <input type="checkbox"/> N <input type="checkbox"/> Unkn <input type="checkbox"/>
Antibiotics:	Y <input type="checkbox"/> N <input type="checkbox"/> Unkn <input type="checkbox"/>	If Yes, list: _____	Tamiflu/ other antiviral drugs:	Y <input type="checkbox"/> N <input type="checkbox"/> Unkn <input type="checkbox"/>			
White cell count total:	_____	Differential neutrophils/lymphocytes%:	_____				
Has the patient been isolated at:	Home <input type="checkbox"/>	Healthcare facility <input type="checkbox"/>	Not isolated <input type="checkbox"/>	Other <input type="checkbox"/>	Specify: _____		

If patient has been isolated at home or at a healthcare facility, please provide date of isolation: DD/MM/YYYY

OUTCOME (at time of specimen submission)

Currently hospitalised:	<input type="checkbox"/>	Discharge date:	DD/MM/YYYY
Discharged	<input type="checkbox"/>	Name of facility:	_____
Transferred	<input type="checkbox"/>	Date of death:	DD/MM/YYYY
Died	<input type="checkbox"/>	Specify:	_____
Other	<input type="checkbox"/>		

¹If patient is a not a permanent resident, please provide their current residential address while residing in South Africa. ²Close contact: A person having had face-to-face contact or was in a closed environment with a COVID-19 case; this includes, amongst others, all persons living in the same household as a COVID-19 case and people working closely in the same environment as a case. A healthcare worker or other person providing direct care for a COVID-19 case, while not wearing recommended personal protective equipment or PPE). A contact in an aircraft sitting within two seats (in any direction) of the COVID-19 case, travel companions or persons providing care, and crew members serving in the section of the aircraft where the index case was seated. ³Areas with presumed ongoing community transmission of SARS-CoV-2: <https://www.nicd.ac.za/wordpress/wp-content/uploads/2020/02/>

Please also complete the contact line list provided and submit with specimen submission form and PUI form to ncov@nicd.ac.za

9.9 Appendix 9 – Contact tracing and contact line list

Initial contact with contact of confirmed case

Each individual on the contact line list will be contacted

- Introduce yourself and specify where you are calling from
- Explain the following:
 - Someone that tested positive for COVID-19 indicated that they were in close contact with them
 - This means that they are at risk and need to be monitored for 14 days after their exposure to the person to monitor symptoms
 - Ask about the last contact with the case and establish if the person is a close contact. See definition of a close contact in guidelines.
 - If person is a close contact, continue with information below. If not, inform person that they have a low risk and should contact their healthcare provider should they develop any symptoms.
- Ask if the person is experiencing any of the listed symptoms on the symptom monitoring tool
 - o If yes:
 - A team will visit them at their home to collect a specimen and to issue them with a thermometer
 - Should the test come back positive, they will be treated for COVID-19
 - Should the test come back negative, we will continue to contact them every day telephonically to monitor their symptoms and should symptoms worsen, we will test them again.
 - This will continue until day 14 after last exposure to the case.
 - o If not:
 - A team will visit them at home and issue them with a thermometer.
 - We will contact them every day telephonically to ask if they are experiencing any symptoms
 - This will continue until day 14 after last exposure to the case.
- During the monitoring period, individuals should self-quarantine at home
 - o This means they should not go to work, school, church, shops, visit friends, have friends or non-household members over, etc.
 - o If the contact is a healthcare worker that cannot take time of work, they should work with a surgical mask if asymptomatic. If symptomatic, they should self-quarantine.
 - o If living with other individuals, the contact and their household members should:
 - Perform hand hygiene frequently, using alcohol-based hand rub if hands are not visibly soiled or soap and water when hands are visibly soiled;
 - Keep distance from affected individual as much as possible (at least 1 meter);
 - Wear a medical mask when in the same room with the affected individual; replacing mask if damp, dispose of the material immediately after use;
 - Clean hands immediately after contact with respiratory secretions;improve airflow in living space by opening windows as much as possible.



COVID-19 CONTACT LINE LIST

Complete a contact line list for every person under investigation and every confirmed Coronavirus disease 2019 (COVID-19) case



Details of person under investigation/confirmed COVID-19 case

NICD Identifier _____ Date Symptom Onset _____
 Surname _____ Name _____
 Contact number _____ Alternative number _____

Travel (provide details of all: 7 days before onset) Travelled by Bus Plane
 Air/bus line _____ Flight/bus # _____ Seat # _____

Details of health official completing this form Today's date _____

Surname _____ Name _____
 Role _____ Facility name _____
 Email address _____ Telephone number(s) _____

Details of contacts (With close contact: from the date of symptom onset, or during symptomatic illness.)

	Surname	First name(s)	Sex (M/F)	Age (Y)	Relation to case ¹	Date of last contact with case	Place of last contact with case (Provide name and address)	Residential address (for next month)	Phone number(s), separate by semicolon	HCW? ² (Y/N) If Yes, facility name
1										
2										
3										
4										
5										
6										
7										
8										

¹ Close contact: A person having had face-to-face contact (≤2 metres) or was in a closed environment with a COVID-19 case; this includes, amongst others, all persons living in the same household as a COVID-19 case and, people working closely in the same environment as a case. A healthcare worker or other person providing direct care for a COVID-19 case, while not wearing recommended personal protective equipment or PPE (e.g., gowns, gloves, NIOSH-certified disposable N95 respirator, eye protection). A contact in an aircraft sitting within two seats (in any direction) of the COVID-19 case, travel companions or persons providing care, and crew members serving in the section of the aircraft where the index case was seated. ² Close from: Spouse, Aunt, Child, Class mate, Colleague, Cousin, Father, Friend, Grandfather, Grandmother, Healthcare worker taking care of, Mother, Nephew, Niece, Other relative, Uncle. ³ Healthcare worker.

Details of contacts (With contact¹ from the date of symptom onset, or during symptomatic illness.)

	Surname	First name(s)	Sex (M/F)	Age (Y)	Relation to case ²	Date of last contact with case	Place of last contact with case (Provide name and address)	Residential address (for next month)	Phone number(s), separate by semicolon	HCW ³ (Y/N) If Yes, facility name
9										
10										
11										
12										
13										
14										
15										
16										
17										
18										
19										
20										
21										

¹ Close contact: A person having had face-to-face contact (≤2 metres) or was in a closed environment with a COVID-19; this includes, amongst others, all persons living in the same household as a COVID-19 case and, people working closely in the same environment as a case. A healthcare worker or other person providing direct care for a COVID-19 case, while not wearing recommended personal protective equipment or PPE (e.g., gowns, gloves, NIOSH-certified disposable N95 respirator, eye protection). A contact in an aircraft sitting within two seats (in any direction) of the COVID-19 case, travel companions or persons providing care, and crew members serving in the section of the aircraft where the index case was seated. ² Chose from: Spouse, Aunt, Child, Class mate, Colleague, Cousin, Father, Friend, Grandfather, Grandmother, Healthcare worker taking care of, Mother, Nephew, Niece, Other relative, Uncle. ³ Healthcare worker.

9.10 Appendix 10 – Contact monitoring tool

PDF version at: <http://www.nicd.ac.za/diseases-a-z-index/covid-19/>



COVID-19 DAILY SYMPTOM MONITORING TOOL

Complete for contact of a confirmed Coronavirus disease 2019 (COVID-19) case



Details of contact of confirmed case (details of case completed just before instructions) NICD Identifier _____ Date of contact _____ Place last contact _____ Surname _____ Name _____ Date of birth _____ Age (Y) _____ Sex M <input type="checkbox"/> F <input type="checkbox"/> Healthcare worker <input type="checkbox"/> Y <input type="checkbox"/> N <input type="checkbox"/> If yes, facility name _____ Contact number(s) _____ Email _____ Physical address _____ House number _____ Street _____ District _____ Province _____ Details of confirmed COVID-19 case Contact type ¹ Close <input type="checkbox"/> Casual <input type="checkbox"/> Relation to case ² _____		Details of health official completing this form Surname _____ Name _____ Role _____ Facility name _____ Email address _____ Telephone number _____ Next of kin details Next of kin name and surname _____ Next of kin contact number _____ Suburb _____ Town _____ Patient traced <input type="checkbox"/> Y <input type="checkbox"/> N <input type="checkbox"/> NICD Identifier _____ Surname _____ DOB _____	
------------------------------------------------------------------------------------------------------------------------------------------------------------------------------------------------------------------------------------------------------------------------------------------------------------------------------------------------------------------------------------------------------------------------------------------------------------------------------------------------------------------------------------------------------------------------------------------------------------------------------------------------------------------------------------------------------------------------------------------------	--	-----------------------------------------------------------------------------------------------------------------------------------------------------------------------------------------------------------------------------------------------------------------------------------------------------------------------------------------------------------------------------------------------------------------------------------------------	--

Instructions for completion: Instructions for completion: Mark "Y" if symptom present and "N" if not. If any symptoms are present collect, contact 082 883 9920 immediately and make immediate arrangements for the collection of a combined nasopharyngeal and oropharyngeal swab. Refer to COVID-19 Quick Guide on the NICD website for additional details. Days post exposure to case.

DAY	1	2	3	4	5	6	7	8	9	10	11	12	13	14
Date (DD/MM)														
Measured body temp														
Chills	<input type="checkbox"/> Y <input type="checkbox"/> N	<input type="checkbox"/> Y <input type="checkbox"/> N	<input type="checkbox"/> Y <input type="checkbox"/> N	<input type="checkbox"/> Y <input type="checkbox"/> N	<input type="checkbox"/> Y <input type="checkbox"/> N	<input type="checkbox"/> Y <input type="checkbox"/> N	<input type="checkbox"/> Y <input type="checkbox"/> N	<input type="checkbox"/> Y <input type="checkbox"/> N	<input type="checkbox"/> Y <input type="checkbox"/> N	<input type="checkbox"/> Y <input type="checkbox"/> N	<input type="checkbox"/> Y <input type="checkbox"/> N	<input type="checkbox"/> Y <input type="checkbox"/> N	<input type="checkbox"/> Y <input type="checkbox"/> N	<input type="checkbox"/> Y <input type="checkbox"/> N
Cough	<input type="checkbox"/> Y <input type="checkbox"/> N	<input type="checkbox"/> Y <input type="checkbox"/> N	<input type="checkbox"/> Y <input type="checkbox"/> N	<input type="checkbox"/> Y <input type="checkbox"/> N	<input type="checkbox"/> Y <input type="checkbox"/> N	<input type="checkbox"/> Y <input type="checkbox"/> N	<input type="checkbox"/> Y <input type="checkbox"/> N	<input type="checkbox"/> Y <input type="checkbox"/> N	<input type="checkbox"/> Y <input type="checkbox"/> N	<input type="checkbox"/> Y <input type="checkbox"/> N	<input type="checkbox"/> Y <input type="checkbox"/> N	<input type="checkbox"/> Y <input type="checkbox"/> N	<input type="checkbox"/> Y <input type="checkbox"/> N	<input type="checkbox"/> Y <input type="checkbox"/> N
Sore throat	<input type="checkbox"/> Y <input type="checkbox"/> N	<input type="checkbox"/> Y <input type="checkbox"/> N	<input type="checkbox"/> Y <input type="checkbox"/> N	<input type="checkbox"/> Y <input type="checkbox"/> N	<input type="checkbox"/> Y <input type="checkbox"/> N	<input type="checkbox"/> Y <input type="checkbox"/> N	<input type="checkbox"/> Y <input type="checkbox"/> N	<input type="checkbox"/> Y <input type="checkbox"/> N	<input type="checkbox"/> Y <input type="checkbox"/> N	<input type="checkbox"/> Y <input type="checkbox"/> N	<input type="checkbox"/> Y <input type="checkbox"/> N	<input type="checkbox"/> Y <input type="checkbox"/> N	<input type="checkbox"/> Y <input type="checkbox"/> N	<input type="checkbox"/> Y <input type="checkbox"/> N
Shortness of breath	<input type="checkbox"/> Y <input type="checkbox"/> N	<input type="checkbox"/> Y <input type="checkbox"/> N	<input type="checkbox"/> Y <input type="checkbox"/> N	<input type="checkbox"/> Y <input type="checkbox"/> N	<input type="checkbox"/> Y <input type="checkbox"/> N	<input type="checkbox"/> Y <input type="checkbox"/> N	<input type="checkbox"/> Y <input type="checkbox"/> N	<input type="checkbox"/> Y <input type="checkbox"/> N	<input type="checkbox"/> Y <input type="checkbox"/> N	<input type="checkbox"/> Y <input type="checkbox"/> N	<input type="checkbox"/> Y <input type="checkbox"/> N	<input type="checkbox"/> Y <input type="checkbox"/> N	<input type="checkbox"/> Y <input type="checkbox"/> N	<input type="checkbox"/> Y <input type="checkbox"/> N
Myalgia/body pains	<input type="checkbox"/> Y <input type="checkbox"/> N	<input type="checkbox"/> Y <input type="checkbox"/> N	<input type="checkbox"/> Y <input type="checkbox"/> N	<input type="checkbox"/> Y <input type="checkbox"/> N	<input type="checkbox"/> Y <input type="checkbox"/> N	<input type="checkbox"/> Y <input type="checkbox"/> N	<input type="checkbox"/> Y <input type="checkbox"/> N	<input type="checkbox"/> Y <input type="checkbox"/> N	<input type="checkbox"/> Y <input type="checkbox"/> N	<input type="checkbox"/> Y <input type="checkbox"/> N	<input type="checkbox"/> Y <input type="checkbox"/> N	<input type="checkbox"/> Y <input type="checkbox"/> N	<input type="checkbox"/> Y <input type="checkbox"/> N	<input type="checkbox"/> Y <input type="checkbox"/> N
Diarrhoea ³	<input type="checkbox"/> Y <input type="checkbox"/> N	<input type="checkbox"/> Y <input type="checkbox"/> N	<input type="checkbox"/> Y <input type="checkbox"/> N	<input type="checkbox"/> Y <input type="checkbox"/> N	<input type="checkbox"/> Y <input type="checkbox"/> N	<input type="checkbox"/> Y <input type="checkbox"/> N	<input type="checkbox"/> Y <input type="checkbox"/> N	<input type="checkbox"/> Y <input type="checkbox"/> N	<input type="checkbox"/> Y <input type="checkbox"/> N	<input type="checkbox"/> Y <input type="checkbox"/> N	<input type="checkbox"/> Y <input type="checkbox"/> N	<input type="checkbox"/> Y <input type="checkbox"/> N	<input type="checkbox"/> Y <input type="checkbox"/> N	<input type="checkbox"/> Y <input type="checkbox"/> N

¹ Close contact: A person having had face-to-face contact (≤2 metres) or was in a closed environment with a COVID-19 case; this includes, amongst others, all persons living in the same household as a COVID-19 case and, people working closely in the same environment as a case. A healthcare worker or other person providing direct care for a COVID-19 case, while not wearing recommended personal protective equipment or PPE (e.g., gowns, gloves, NIOSH-certified disposable N95 respirator, eye protection). A contact in an aircraft sitting within two seats (in any direction) of the COVID-19 case, travel companions or persons providing care, and crew members serving in the section of the aircraft where the index case was seated. Casual contact: Anyone not meeting the definition for a close contact but with possible exposure. ² Choose from: Spouse, Aunt, Child, Class mate, Colleague, Cousin, Father, Friend, Grandfather, Grandmother, Healthcare worker taking care of, Mother, Nephew, Niece, Other relative, Uncle. ³ Diarrhoea defined as three or more loose stools in a 24-hour period.

9.11 Appendix 11 – Response to suspected case at port of entry

Standard operating procedure for the management of suspected communicable disease at the points of entry and transportation to a designated hospital

1. INTRODUCTION

Port Health Service (PHS) is defined as the first line of defence to protect the citizens of South Africa and visitors against the health risks associated with cross border movement of people, conveyances, baggage, cargo shipments and other imported consignments. It is thus vital for all points of entry to be on the alert and prepared to respond to a possible importation of a communicable disease, whether intentional or unintentional.

The following standard operating procedures detail measures that must be implemented by Port Health officials in preventing and responding to a suspected case of COVID-19.

2. SCREENING MEASURES

2.1 Screening Procedures

- a) Port Health Officials (PHO) must monitor all arriving conveyances from the affected countries and increase surveillance measures.
- b) Surveillance measures must be enhanced on conveyances arriving from high risk areas.
- c) Upon arrival of the conveyance, PHO must collect and verify the health documentation and interview the crew member/operator to determine if there is any sick passenger on board.
- d) In addition to the routine interview of crew members/operators, PHO must ask crew members questions specific to signs and symptoms of COVID-19.
- e) PHO must screen all travellers utilising non-invasive thermometer.
- f) Travellers with normal temperature may be allowed to proceed.
- g) If traveller is found to have a high temperature, he/she must be informed of such and must be assessed further by clinical staff where available.
- h) If traveller conforms to the case definition, the suspect case must be transported by emergency medical services to a designated hospital for further management.
- i) Where a clinical staff is not available, port health must interview the traveller and if determined to conform to the case definition the traveller must be kept in isolation until such time as emergency medical services transport the traveller to a designated hospital. PHO must inform the NICD and Provincial CDC coordinators.
- j) Where thermal scanners are available, all travellers who were not found to have an elevated temperature during the non-invasive thermometer screening must be channelled through the secondary screening utilising a thermal scanner
- k) Travellers found to have elevated temperature must be escorted to the Port Health Clinic where available, for further examination and must be interviewed to determine their travel history.
- l) Where Port Health Clinic is not available, Port Health must interview the traveller/s to determine if the traveller/s meet the case definition for PUI.
- m) If traveller meets the case definition for PUI COVID-19, the suspect case must be kept in isolation until he/she is transported to a designated hospital for further management (see table below).

Traveller Health Questionnaires

NB! All travellers arriving directly from countries and who have visited China or travellers who had travelled to areas where there is community transmission of COVID-19 in the past 14 days must complete a traveller health questionnaire. All questionnaires must be reviewed in real time analysed and information captured electronically.

Table 2 : Hospitals and contact persons for hospitals designated to receive PUI/confirmed cases

PROVINCE	2019-nCoV DESIGNATED HOSPITAL NAME	CEO	IPC
LIMPOPO	Polokwane Hospital	Mr Ramawa: 081 494 6995	Ms Maronel Kruger: 079 978 7984
MPUMALANGA	Rob Ferreira	S FG Nyathi : 071 682 6396 / 013 741 6307	Ms Francina: 079 365 5522
GAUTENG	Charlotte Mexeke	Ms Gladys Bogoshi: 082 9273 565	Mr Malebati : 082 332 8501
	Steve Biko Academic Hospital	Dr M Mathebula: 082 907 0973	
KWAZULU-NATAL	Greys Hospital	Dr Ben Bilenge: 083 555 1563	Sr Jennifer Green 074 311 3330
NORTH WEST	Klerksdorp Hospital	Dr Dikhing Mahole: 082 566 1146	Sr Mojaki Mosiatlhaga: 082 450 6116
FREE STATE	Pelonomi Hospital		
NORTHERN CAPE	Kimberley Hospital	Allister Katana: 072 560 9990	S Maritjie Langevelt: 084 467 6888
EASTERN CAPE	Livingston Hospital	D Makamba: 082 854 1155	
WESTERN CAPE	Tygerberg Hospital	Dr Dimitri Erasmus: 082 455 0824 / 0219384136 COO: Dr Paul 021 938 5883	Maria Aucamp: 021 938 5065/5054 Dr Jantjie: 083 419 1452 / 0219389645 Dr Jack Meintjies: 021 938 5563/ 5053/ 5054

3 IN THE EVENT OF PERSON UNDER INVESTIGATION ONBOARD THE CONVEYANCE

3.1 Prior to arrival of conveyance

- a) If traveller presents with symptoms related to a communicable disease while on board a conveyance;
 - In case of airport/sea port the tower/captain will inform Operations/Agent who must inform PHO of the ill passenger,
 - In case of land port, PHO will be informed on arrival of the conveyance at the port.
- b) Suspected case is moved to an isolated area on the conveyance, if sufficient space is available.
- c) Nurse or PHO must contact the NICD to confirm whether the symptoms meet the 2019-nCoV PUI case definition;
- d) Based on the information provided, Port Health must notify and make arrangements with the designated health facilities and ambulance for transportation of the ill traveller.
- e) Port Health must then notify the relevant Provincial Communicable Disease Control Coordinator.

3.2 Once the conveyance has arrived at the Point of Entry

- a) PHO must board the conveyance, together with the clinical personnel and ensure entrance to the conveyance is secured and no person enters or leaves the conveyance.
- b) PHO must obtain and confirm the following information from the crew member:

- number of cases,
 - signs and symptoms;
 - vector control measures, where required and
 - collect and verify the required health documentation and passenger list;
- c) PHO must brief the passengers that there is a possible case of COVID-19 on board, calm them and provide the necessary health information, including, reporting to the nearest health facility and inform the health worker of their travel history should they experience any symptoms;
 - d) PHO must identify the contacts and allow all passengers except the sick passenger and contacts to disembark;
 - e) **Sick passenger may then be escorted from the aircraft and transported to the designated health facility (see section 5 below: Medical Evacuation Procedure);**
 - f) Passenger locator cards and health information must be handed out to the contacts and inform them that they will be contacted for monitoring purposes;
 - g) Contacts may then be allowed to disembark and channelled through thermal screening processes.
 - h) Port Health must hand over passenger list and close contact details to Provincial Communicable Disease Control Coordinator (contact details in table below) for further monitoring;
 - i) The ground handling and cleaning company of the conveyance operators should be notified at the same time so that preparations can be made for appropriate cleaning and/or disinfection of the conveyance after passengers have disembarked; if required;
 - j) PHO must monitor the entire cleaning and/or disinfection process.

Table 3: Contact details of Communicable Diseases control coordinators

Province	CDC coordinator	Contact number/s
ECP	Mr. T Dlamini Ms. N Mgobo	083 378 0189 060 579 9027
FSP	Ms. B Nyokong Ms. D Baleni	083 757 8217/051 408 1734 082 463 7499
GP	Dr. Asomugha Ms. C Kesebilwe	082 330 1490 083 490 8165 / 011 355 3867
KZN	Ms. P Govender	071 609 2505
LP	Ms. M.F. Ngobeni Ms. M.P. Mudau	079 491 1909 / 015 293 6062 071 678 3864
MP	Mr M Zwane Ms. H Mpangane	082 229 8893 / 013 766 3078 076 522 8511 / 013 766 3411
NCP	Ms. Gloria Hottie	072 391 3345 / 053 830 0529
NWP	Ms C Lebeke	082 421 7985 / 018 397 2600
WCP	Ms C Lawrence	072 356 5146 / 021 483 9964

4 MANAGEMENT OF INTENTIONAL TRANSPORTATION OF A SICK PASSENGER INTO SOUTH AFRICA/CONFIRMED CASE

- a) Conveyance operators or medical companies transporting patients to South Africa for medical attention by commercial flight, charter flight or road ambulances must notify PHO beforehand utilising notification Form AC1 and include the medical history of the patient.
- b) Form AC2 must be completed by the medical crew for information on the symptoms of the patient.
- c) For patients arriving from the affected countries, Port Health must consult with the NICD and the Chief Director: Environmental Health & Port Health Services before a decision is taken to approve or disapprove the transportation of the patient.
- d) If approval to transport the patient is granted, PHO must issue Form PH1 to the applicant.

- e) In instances where a patient develops symptoms related to a communicable disease before or during transportation, the AC2 form must be completed and handed over to the PHO upon arrival at the airport.
- f) Port Health Officials and Port Health Nurse must assess the patient upon arrival and inform the hospital receiving the patient of the condition.
- g) All information related to the passenger must be communicated to the Provincial CDC and NICD to conduct a follow-up on the case.
- h) Port Health Official or Port Health Nurse must follow up with the hospital to receive an update prior to closing the file.
- i) Port Health Officials (PHO) must monitor all arriving conveyances from the affected countries and increase surveillance measures.
- j) Upon arrival of the conveyance, Port Health Officials must collect and verify the health documentation and interview the crew member/operator to determine if there is any sick passenger on board.
- k) In addition to the routine interview of crew members/operators, Port Health Officials must ask crew members questions specific to signs and symptoms of COVID-19.
- l) If PHO is certain that there are no sick passengers on board and all health requirements have been met, the passengers may be allowed to disembark.
- m) All arriving travellers must be channelled through the thermal scanning processes.
- n) Travellers found to have elevated temperature must be escorted to the Port Health clinic where available, for further examination and must be interviewed to determine their travel history.
- o) Where Port Health Clinic is not available, Port Health must interview the traveller with elevated temperature to determine their travel history, record the details of the traveller and if required transfer the traveller to the nearest health facility.
- p) Travellers presenting with any one of these symptoms; fever, cough, headache, joint and muscle aches, sore throat, and weakness, diarrhoea, vomiting, stomach pain and have travelled to the affected countries must be isolated and arrangements be made for transportation of the traveller to the nearest designated health facility for further management.

5 MEDICAL EVACUATION PROCEDURE

This section is referenced from the **STANDARD OPERATING PROCEDURE FOR THE RECOGNITION AND MANAGEMENT OF A SUSPECTED OR CONFIRMED NOVEL CORONAVIRUS PATIENT**. The SOP can be accessed from: <http://www.health.gov.za/index.php/shortcodes/2015-03-29-10-42-47/2015-04-30-08-29-27/2015-04-30-08-33-30>

1.1 Suspected/Confirmed COVID-19 medical evacuation procedure

- The provincial Emergency management Services (EMS) manager must be contacted when an ambulance is requested to transfer a suspected or confirmed COVID-19 patient to and from a designated /referral hospital. (Annexure 8: Provincial EMS Managers' contact details)
- The Provincial CDC must be informed prior to EMS medical evacuation of any suspected/confirmed 2019-nCoV patient.
- Driver must not have any contact with patient and must act as liaison
- Ideally two trained EMS specialized response team personnel must accompany patient.
- Hand hygiene must be observed before and after every contact with patient.
- Don correct PPE.
- Focus of care is supportive and maintaining existing treatment. No invasive procedures should be done in transit. (No sharps to be used)
- Keep contact with designated referral hospital. Determine and communicate an estimated time of arrival (ETA) and report an update on patient's condition, as hospital needs to prepare: - isolation ward needs to be prepared, staff need to don PPE, security needs to clear public and staff from entrance and route.

- When arriving at hospital, the patient is to be kept inside ambulance until hospital indicates that the patient is allowed to enter.
- Provincial CDC must be informed after every COVID-19 transfer; crew must be placed on 14-day contact list and must submit temperature readings twice a day.

1.2 Unsuspected COVID-19 EMS medical evacuation procedure

- Normal call out to a home or healthcare facility and/ or after transporting has commenced, a suspicion for a possible COVID-19 case is raised.
- Immediately contact and report to Provincial CDC who will assist in advice and decision on where to take patient.
- Driver must not have any contact with patient and must act as liaison.
- Hand hygiene must be observed before and after every contact with patient.
- EMS personnel must Don correct PPE.
- Focus of care is supportive and maintaining existing treatment. No invasive procedures should be done in transit. (No sharps to be used)
- Keep contact with designated referral hospital. Determine and communicate an estimated time of arrival (ETA) and report an update on patient's condition, as hospital needs to prepare: - isolation ward needs to be prepared, staff need to don PPE, security needs to clear public and staff from entrance and route.
- When arriving at hospital, the patient is to be kept inside ambulance until hospital indicates that the patient is allowed to enter.
- Provincial CDC must be informed after every COVID-19 transfer, crew must be placed on 14-day contact list and must submit temperature readings twice a day.

1.3 Medical evacuation procedure of COVID-19 patient to and from a Healthcare facility

- When arriving at the healthcare facility, the patient and clinical team will remain inside the ambulance or isolation ward. The driver will liaise with healthcare staff and only after the indication from healthcare staff has been given that they are ready to receive/transfer the patient, can the patient be taken to/from the ambulance/isolation ward.
- Driver must ensure that healthcare facility is ready to receive or transfer the patient and that public are cleared from entrance and route that patient will be moved along.
- During the movement of the patient, ensure that all spills are immediately cleaned and decontaminated on the route that patient was moved.

1.4 Cleaning and decontamination

- Crew decontaminating the ambulance should wear correct PPE.
- During or after transport of a COVID-19 patient, vomitus, blood and other spillages should be flooded with disinfectant, namely chlorine solution with a concentration of 5000 ppm (0.5%) or 20x30g sachets of Biocide D Extra/10L water, covered with paper towels or absorbent material and left for at least 30 minutes before cleaning.
- Never use high pressure jet spray inside confined space of ambulance.
- Physical material like blood and vomitus must first be cleaned up and removed before terminal cleaning can start.
- All surfaces should be wiped down and washed at least two times, with 500 ppm (0.05%) chlorine solution. **Vehicle is ready to use again immediately after cleaning.**
- Containers with secretions, excretions and other waste products such as vomitus and blood should be flooded with a copious amount of disinfectant, namely chlorine solution with a concentration of 5000 ppm (0.5%) or 20x30g sachets of Biocide D Extra/10L water, for at least 30 minutes.
- All items leaving the ambulance should be enclosed and sealed in adequate layers of appropriate bags to prevent leakage. The outer surfaces of the bags should be wiped with chlorine disinfectant at a concentration of 0.05% (500 ppm) and labelled as bio hazardous. Disposable equipment should be

disposed of by incineration (as per normal Health Care Waste Management (HCWM) Regulation Act 59, 2008), non-disposable equipment can be washed and disinfected (Autoclaved).

- If sharps bin, for any reason, was used it needs to be wiped down and placed inside plastic bag. Bag is wiped again and placed inside double red bag and sealed in waste box that should then be clearly marked as containing sharps.

1.5 Handling of Health care waste

- As per normal HCWM Regulation, ensure that waste is safely stored until the health care waste management company can pick it up. Ensure that the company knows and acknowledges that waste was generated by suspected or confirmed COVID-19 case.
- All bags, bins and boxes must be adequately sealed, as not to leak any fluids, and must be wiped down with 0.05% chlorine solution before being stored or removed.

1.6 Handling of Suspected or Confirmed COVID-19 case mortal remains.

- If patient dies in transit, the EMS Provincial coordinator and Provincial CDC must be notified. A decision on where to take the corpse must be communicated to the ambulance crew.
- Provincial Environmental Health must be informed.
- Under no circumstances will the corpse be removed from ambulance other than at assigned facility that was communicated to ambulance crew.
- The corpse must be placed in double body bags that are fluid leak proof. The bags must be wiped down with a 0.05% chlorine solution before leaving the ambulance.
- The removal of a suspected COVID-19 corpse must be done under the directive of Environmental Health.

Annexure 11.1:
Flow diagram depicting the approach to an imported PUI/suspected or confirmed case of infectious disease at port of entry (PoE)

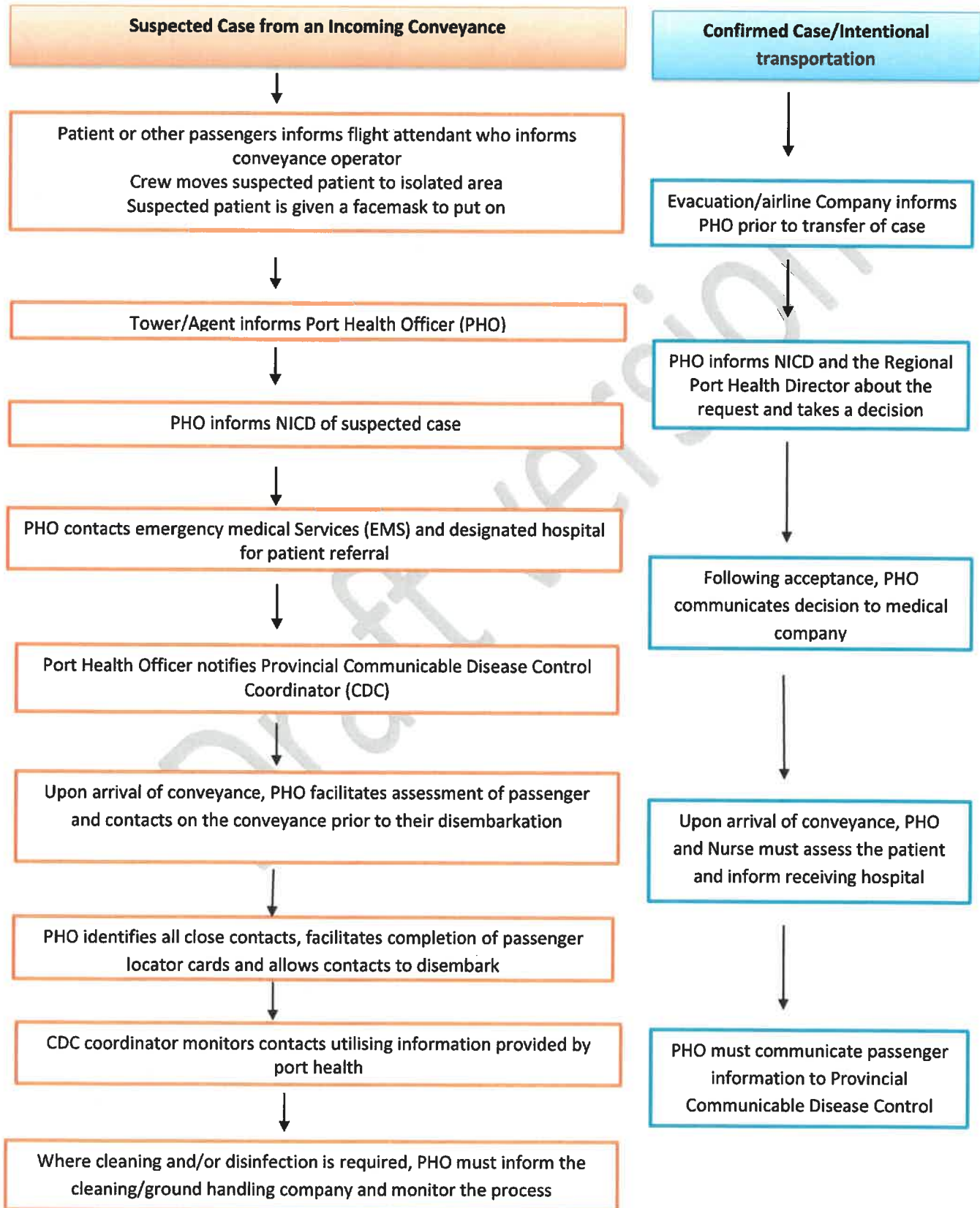

Annexure 11.2:

The flow diagram depicts the process flow for the management of a suspected or possible case from a country/area reporting outbreak of contagious infectious disease

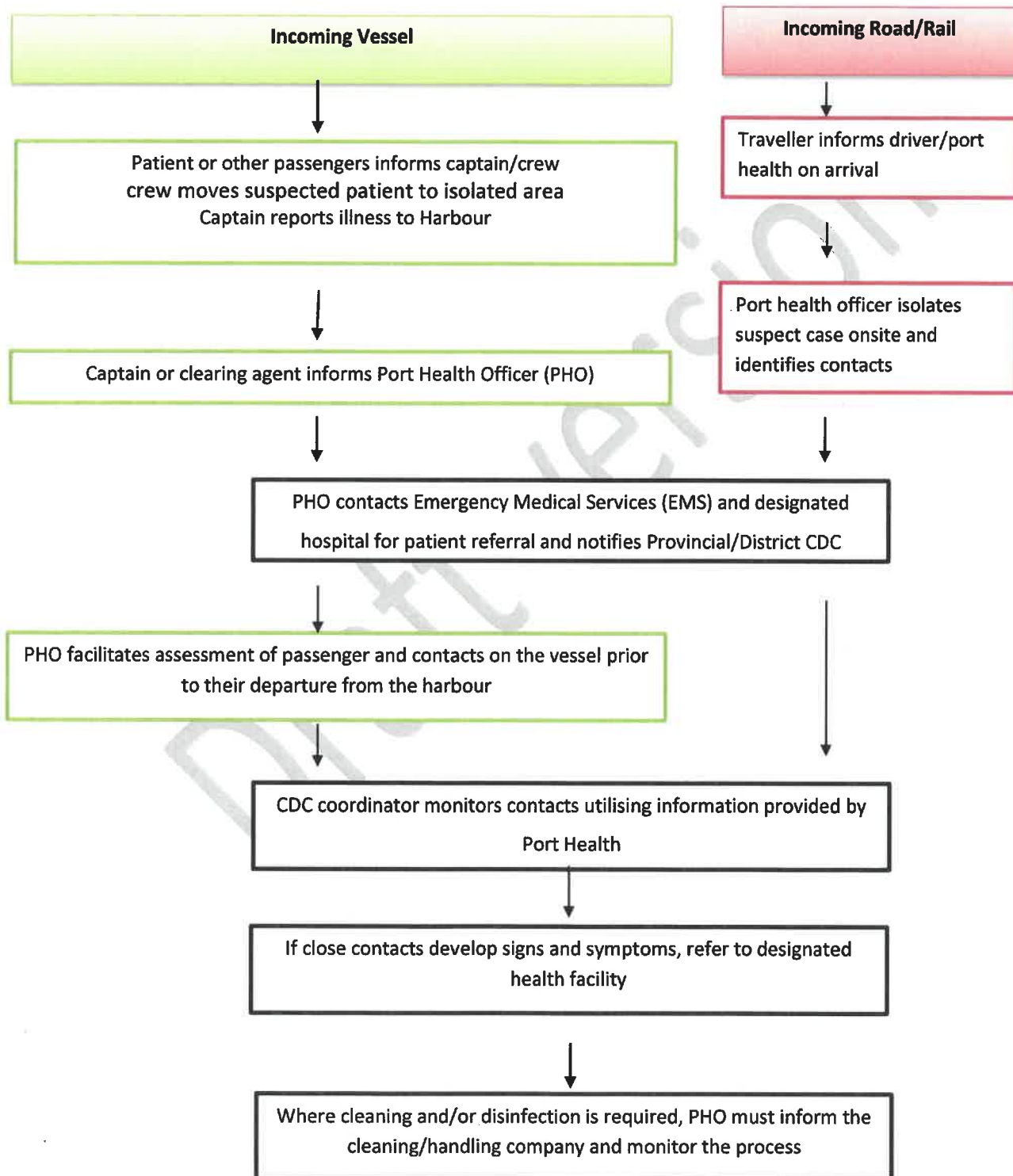

9.12 Appendix 12 – Guidelines for the safe handling of human remains of confirmed/suspected COVID-19 case and repatriation of human remains of confirmed/suspected COVID-19 case

- The human remains of a person who has died of a confirmed COVID-19 should be cremated.
- Where cremation is not possible, the repatriation of human remains who died of confirmed/suspected COVID-19 must be conducted in line with the Regulations Relating to the Management of Human Remains (Regulation 363 of 22 May 2013).
- A formal request for an import/export permit issued by the Director-General: Health must be made by the Department of International Relations and Cooperation (DIRCO) or through the embassies, prior to importation/exportation of the human remains.
- Once a permit has been issued by the Director-General, the human remains may be transported.
- The human remains must not be embalmed and shall be transported under the following precautions:
 - Be placed in leak proof triple body bag and in a non-transparent sealed coffin,
 - The first two body bags must be transparent and sealed and the third body bag non-transparent and not sealed
 - After the body has been placed in the triple body bag, the remains must be placed in a non-transparent coffin which is lined with 5cm saw dust to prevent any potential leakages.
- The import/export permit, death certificate and written declaration by an institution responsible for packaging the human remains that transportation of human remains will not constitute a health hazard must accompany the human remains at all times.
- No person must open the coffin or remove the human remains after they have been sealed without prior approval from an Environmental Health Practitioner.

In the case of importation;

- Environmental Health Practitioner (EHP) at a point of entry must inform forensic pathology of the arrival of the human remains for transportation to a mortuary of the designated hospital.
- EHP at a point of entry must monitor the removal of the remains from the conveyance to the forensic pathology vehicle.
- EHP at a Municipal level must monitor the handling of the human remains after arrival at the designated mortuary.

In the case of exportation;

- The human remains must be transported from the mortuary of a designated hospital to the point of entry by Forensic Pathology in consultation with the embassy of which the deceased holds residence.
- EHP at a Municipal level must monitor the handling of the human remains at the designated mortuary.
- EHP at a point of entry must monitor the removal of the human remains from the forensic pathology vehicle to the conveyance.

Management (handling, movement, storage and burial) of human remains of a person who died of COVID-19

- Handling of the Human Remains must be strictly monitored by **EHP** throughout the process.
- Human remains shall be placed in a leak proof triple body bag both first two bags shall be transparent and sealed while the third one shall be non-transparent and unsealed.
- After the body has been placed in the triple body bag, the remains must be placed in a non-transparent coffin.
- The human remains must be transported in a manner that is in compliant with the provisions of the Regulations Relating to the Management of Human Remains.
- The Human remains are considered contagious and should be kept only in designated health facilities' mortuaries.
- Human Remains can only be transferred from one designated facility to another designated facility or from such to a cemetery or crematorium.
- Under no circumstances shall the human remains be directly handled, whether for aesthetic, hygiene preparations, cultural or religious reasons.
- The human remains may not be embalmed or viewed by breaking the seals of first two bags but by opening the third bag.
- Where it is feasible and acceptable to family culture and/or religion, it is strongly recommended that the remains be cremated.
- In all cases, remains should not be kept in households for vigil or any purpose but be kept in designated health facility mortuary premises and directly transported from designated health facility mortuary straight to place of burial or cremation or the home on the day of burial/cremation.
- The body should be buried in a sufficiently deep grave to prevent access by rodents and carnivores.
- Human remains shall be placed in a triple body bag both first two bags shall be transparent and sealed while the third one shall be non-transparent and unsealed zip-up body bag with handles and appropriate BIOHAZARD warning tag written "hazard Group 4 Pathogens" before transporting to designated health facility mortuary.

- All bags, bins and boxes must be adequately sealed, as not to leak any fluids, and must be wiped down with 0.05% chlorine solution before being stored or removed.

1.7 Handling of Suspected or Confirmed COVID-19 case mortal remains.

- If patient dies in transit, the EMS Provincial coordinator and Provincial CDC must be notified. A decision on where to take the corpse must be communicated to the ambulance crew.
- Provincial Environmental Health must be informed.
- Under no circumstances will the corpse be removed from ambulance other than at assigned facility that was communicated to ambulance crew.
- The corpse must be placed in double body bags that are fluid leak proof. The bags must be wiped down with a 0.05% chlorine solution before leaving the ambulance.

9.13 Appendix 13 – Communicable Diseases Outbreak Report Format

TITLE	
PERIOD	
LOCATION	
DISTRICT	
PROVINCE	

Executive summary

.....

I. Introduction:

- Background
- Reasons for investigation (public health significance, threshold met, etc.)
- Investigation and outbreak preparedness

II. Methods:

- Dates of investigation
- Site(s) of investigation (health care facilities, villages, other)
- Case finding (indicate what was done regarding case finding, e.g., register review, contact investigation, alerting other health facilities, other)
- Lab specimen collection
- Description of response and intervention (include dates)
- Data management

III. Results:

- Date and location of first known (index) case
- Date and health facility where first case was seen by the health care system
- Results of additional case finding
- Lab analysis and results
- With text, describe key features of results of time, place, and person analysis
- For detailed results by time (epi curve), place (map), and person characteristics (tables) and line lists
- Results of response and evidence of impact

IV. Self-evaluation of the timeliness and quality of preparedness, outbreak detection, investigation, and response

Epidemic Preparedness

Indicator	Yes	No
Were adequate medical supplies available at the onset of the outbreak		
Were clinical guidelines available to health workers?		
Does the district epidemic management committee regularly meet as part of epidemic preparedness?		

Outbreak Detection

Indicator	Date 1	Date 2	Interval
Interval between onset of index case (or occurrence of an unusual cluster at the community level) [date 1] to arrival of first outbreak case at the health facility [date 2] (Target: <3 days)			
Interval between initial outbreak case seen at the health facility (or date of outbreak threshold crossing at the health facility) [date 1] and reporting to the district health team [date 2] (Target: within 24 hours)			
Cumulative interval between onset of index case (or occurrence of an unusual cluster at the community or health facility) [date 1] to notification to the district [date 2] (Target: <7 days)			

Outbreak Investigation

Indicator	Yes	No
Were case forms and line lists completed?		
Were laboratory specimens taken (if required)?		

Indicator	Date 1	Date 2	Interval
Interval between notification of district [date 1] and district field investigation conducted [date 2] (Target: within 48 hours)			
Interval between sending specimens to the lab [date 1] and receipt of results by the district [date 2] (Target: 3-7 days, depending on type of test)			

Outbreak response:

Indicator	Date 1	Date 2	Interval
Interval between notification of outbreak to district [date 1] and concrete response by the district [date 2] (Target: within 48 hours of notification)			

Evaluation and Feedback:

Indicator	Date 1	Date 2	Interval
Interval between end of the outbreak [date 1] and finalization of outbreak report with case forms/line list sent to national level [date 2] (Target: 2 weeks)			
Indicator	Yes	No	
Did the outbreak management committee meet to review investigation results?			
Was feedback given to health facilities and community?			

V. Evaluation of other aspects of the response:

.....
.....

VI. Interpretations, discussion, and conclusions:

.....
.....

VII. Recommended public health actions:

Comment on following levels: community, health facility, district, partners, provincial, and national

.....
.....

District Epidemic Committee Chairperson:

Name: _____

Signature: _____

Date report completed: _____

9.14 Appendix 14 – Contact details (email address and telephone) of stakeholders involved in supporting outbreak response.

Institution/Province	Name	Email address	Telephone number
National Department of Health			
Communicable Disease Control	Tsakani Furumele	Tsakani.Furumele@health.gov.za	012 395 8096 / 0824199686
Malaria, Vector-borne and Zoonotic Diseases	Devanand Moonasar	Patric.Moonasar@health.gov.za	082 578 3107
	Wayne Ramkrishna	Wayne.Ramkrishna@health.gov.za	082 317 4687
Port Health	Funeka Bongweni	Funeka.Bongweni@health.gov.za	012 395 9728 / 0609930107
Environmental Health	Murdock Ramathuba	Murdock.Ramathuba@health.gov.za	012 395 8518 / 0814150093
Emergency Medical Services	Raveen Naidoo	Raveen.Naidoo@health.gov.za	012 395 821
	Ahmed Bham	Ahmed.Bham@health.gov.za	012 395 9636 / 0735716392
Hospital Services	Keneilwe Modise	Keneilwe.Modise@health.gov.za	012 395 8257 / 0829648888
Infection Prevention and Control	Ronel Steinhobel	Ronel.Steinhobel@health.gov.za	012 395 9198 / 0836275661
Provincial Communicable Disease Control Directorate			
Eastern Cape	Thomas Dlamini	thomas.dlamini@echealth.gov.za	083 378 0189
Free State	Dikeledi Baleni	balenid@fshealth.gov.za	083 757 8217
	Babsy Nyokong	nyokongb@fshealth.gov.za	082 463 7499
Gauteng	Chika Asomugha	Chika.Asomugha@gauteng.gov.za	082 330 1490
	Caroline Kesebilwe	Caroline.kesebilwe@gauteng.gov.za	083 490 8165
KwaZulu-Natal	Premi Govender	premi.govender@kznhealth.gov.za	071 609 2505
Limpopo	Marlene Freda Ngobeni	Marlene.Ngobeni@dhsd.limpopo.gov.za	079 491 1909

	Mashudu P. Mudau	Prudence.Mudau@dhsd.limpopo.gov.za	071 678 3864
Mpumalanga	Mandla Zwane	MandlaZw@mpuhealth.gov.za	082 229 8893
	Hluphi Mpangane	hluphim@mpuhealth.gov.za	076 522 8511 013 766 3411
North West	Chriseldah Lebeko	clebeko@nwp.gov.za	082 421 7985
Northern Cape	Gloria Hottie	hottieg@webmail.co.za	072 391 3345 053 830 0529
Western Cape	Charlene Jacobs	Charlene.Jacobs@westerncape.gov.za	072 356 5146 021 483 9964
Port Health and Environmental Health			
Central Region (Gauteng, Free-State, Northern Cape)	Funeka Bongweni	Funeka.Bongweni@health.gov.za	012 395 9728 060 993 0107
Northern Region (Limpopo, Mpumalanga, North West)	Ockert Jacobs	Ockert.Jacobs@health.gov.za	012 395 9417 082 372 0556
Coastal Region (KwaZulu Natal, Northern Cape, Western Cape)	Antoinette Hargreaves	Antoinette.Hargreaves@health.gov.za	031 301 0381 083 460 0935
Emergency Medical Services (EMS)- see table below			
National Institute for Communicable Diseases (NICD)			
Hotline (24-hours)	Doctor-on-call		082 883 9920
Deputy Incident Manager	Ann Mathews	annm@nicd.ac.za	066 0463581
Laboratory	Anne von Gottberg	annev@nicd.ac.za	082 572 0057
	Nicole Wolter	nicolew@nicd.ac.za	083 285 8708
	Jinal Bhiman	jinalb@nicd.ac.za	066 363 4511
Case Management	Kerrigan McCarthy	kerriganm@nicd.ac.za	0798717278

Epidemiology and Surveillance	Sibongile Walaza	sibongilew@nicd.ac.za	083 657 4741
	Jackie Kleynhans	jackiek@nicd.ac.za	
	Genevie Ntshoe	genevien@nicd.ac.za	
Designated Hospitals			
Eastern Cape:			041 405 2255
Livingston Hospital			
Free State:			051 405 1911
Pelonomi Hospital			
Gauteng:			011 717 1000
Charlotte Maxeke Johannesburg Academic Hospital			
Steve Biko Academic Hospital			012 354 1000
KwaZulu-Natal:			033 897 3000
Greys Hospital			
Limpopo:			015 287 5000
Polokwane Hospital			
Mpumalanga:			013 741 6100
Rob Ferreira Hospital			
North West:			018 406 4600
Klerksdorp Hospital			
Northern Cape:			053 802 9111
Kimberley Hospital			
Western Cape:			021 938 5454
Tygerberg Hospital			

Provincial EMS Managers

PROVINCE	Contact Details	Contact Persons
National Department of Health: EMS & Disaster Medicine Directorate	012 395 9636 / 081 324 4555 012395 9636 / 073 571 6392	Mr Raveen Naidoo (Director) Mr Ahmed Bham (EMS Operational Manager – Disaster Medicine)
Gauteng	011 564 2211 / 072 433 7450 011 564 2021	Mr. J.P. Von Benecke Mr Kgati Malebane (Director EMS)
Western cape	012 937 0300 082 568 6489 / 021 948 9908	Mr. Arthur van Heerden Dr S De Vries (Director EMS)
Kwazulu Natal	0834571242 083 501 1955 / 033 846 7237	Mr M Mabaso Ms B Zungu (Director EMS)
Free State	0609856082 082 659 1600 / 051 408 1855	Mr R Ruiters (Provincial EMS Ops Manager) Dr Joe Khoali (Director EMS)
North West	082 335 6034 / 018 473 0324	Mr B Redlinghys (Director EMS)
Limpopo	082 040 5494 082 440 0802 / 015 295 2999	Mr F Masegela Dr Clive Sibanda (Director EMS)
Northern Cape	053 802 2280 / 053 831 1954/5 083 335 6034 / 053 831 2884	Mr R. Dreyer Mr M Ntintelo (Director EMS)
Mpumalanga	013 753 2288/ 082 907 3256 013 766 3302 / 082 828 6223	Mr. Scosh Mkhonto Mr Zungu (Director EMS)
Eastern Cape	060 572 9172 / 060 572 9172	Mr AK Munilil (Director EMS)